

⚠ WARNING

Risk of electrical shock. Disconnect power before servicing or installing luminaire.

⚠ WARNING

Risk of injury or damage. Luminaire will fail if not installed properly. Follow installation instructions.

⚠ WARNING

Risk of injury. Wear safety glasses and gloves during installation and servicing. Allow ample time to cool before handling.

IMPORTANT SAFETY INSTRUCTIONS

- Read all installation instructions before installing. It is important to save these instructions.
- Only install and connect LED module with power disconnected at the circuit breaker. Hot plugging, or connecting the module with power on, could damage the LEDs and is not covered by warranty.
- Observe and follow all label information and instructions regarding dry, damp and wet location listings, proper Intense LED module, warnings of installation near combustible materials and/or insulation.
- Be sure to connect ground wire to prevent electric shock or other potential hazards.
- The product must be installed in a manner consistent with the intended use and in compliance with the national electrical codes and local codes by a person familiar with the construction and operation of the product and the hazards involved.
- **WARNING:** Use only Intense Lighting trims listed for use with this fixture. Use of trims other than those listed by Intense Lighting is a violation of N.E.C 110-3(B) and voids all warranties.

ATTACH MOUNTING BRACKET TO JUNCTION BOX:

1. Attach the mounting bracket to junction box using hardware supplied with junction box.

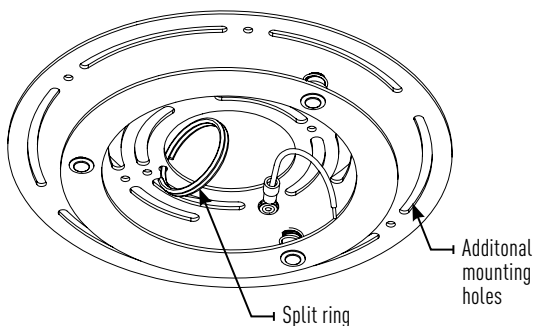

ELECTRICAL CONNECTIONS:

1. Attach the safety cable from the cylinder to split ring on the mounting bracket.
2. Make electrical connections through center hole of the mounting bracket.
3. Connect ground wire from mounting bracket to green (ground) supply wire and ground wire from fixture, black wire from cylinder to black (hot) supply wire and white wire from cylinder to white (neutral) supply wire. Use UL listed connectors or wire nuts (by others) to make the connections. Connect dimming wires if applicable, see page 3.

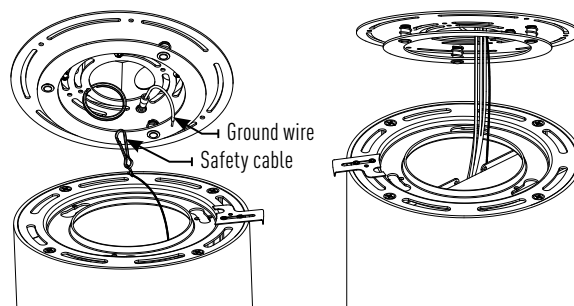

MOUNTING CYLINDER TO MOUNTING BRACKET:

1. Pull out the locking tab on the cylinder's top plate.
2. Align the keyholes on the cylinder's top plate with the spring standoffs.
3. Lift the cylinder into the spring standoffs and rotate the cylinder clockwise.
4. Make sure the gap between the ceiling and cylinder is even to ensure the fixture is installed correctly.

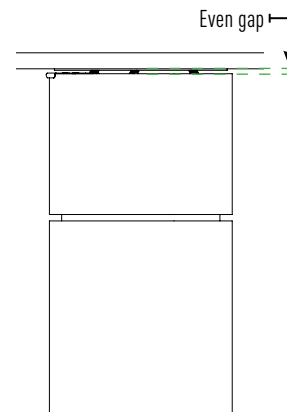
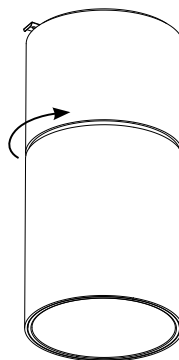
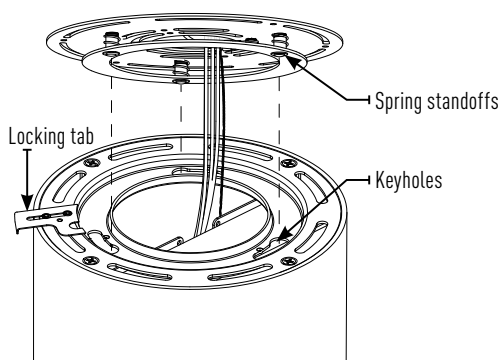

LOCKING CYLINDER:

1. Push in the locking tab to lock the cylinder into the spring standoff bracket.

4

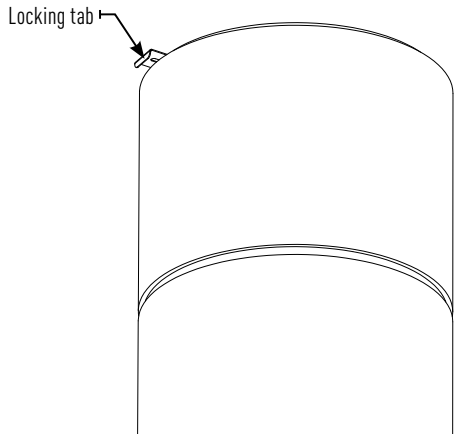

MAINTENANCE:

1. Pull out the locking tab on the cylinder's top plate. Lift up and rotate the cylinder counter clockwise to release it from the mounting bracket.
2. Disconnect wires from junction box and disconnect the safety cable from split ring if applicable.
3. Remove all four M4 x 10mm flat head fasteners and lid.
4. Remove two 8-32 nuts from the driver and keep for replacement.
5. Replace new driver on driver plate, see wiring diagram on page 3.

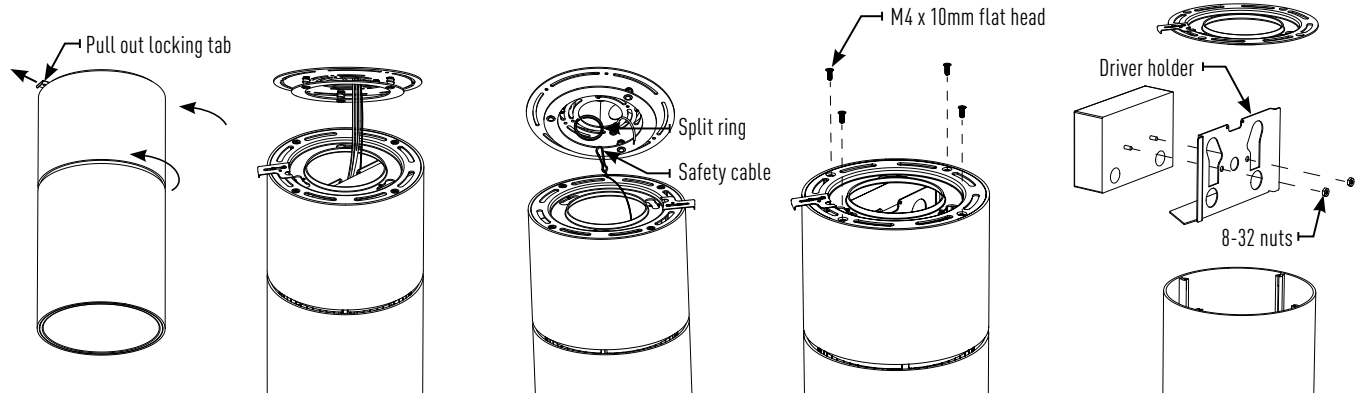

REPLACING OPTICS / INSTALLING ACCESSORIES:

1. Remove trim, then remove optic holder from cylinder.
2. Remove retaining ring that secures optic, then remove optic.
3. Install accessory in optic holder and/or insert new optic.
4. Secure retaining ring and replace optic holder then trim.

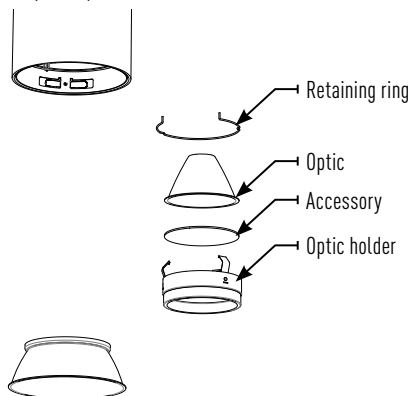

0-10V DIMMING (10% Dimming, eldoLED 1%, eldoLED 0.1%)

- 120V/277V
- Dims down to 10% light output
- Consult dimming manufacturer for installation instructions and power packs

COMPATIBLE DIMMERS

Manufacturer	Part Number(s)
HUNT	PS-010-IV-120V, PS-010-WH-120V, PS-010-3W-IV-120, PS-010-3W-WH-120V, PS-010-IV-277V, PS-010-WH-277V, PS-010-3W-IV-277V, PS-010-3W-WH-277V, FD-010: PS-IFC-010-IV, PS-IFC-010-WH-120/277V, FD-010: PS-IFC-010-3W-IV, PS-IFC-010-3W-WH-120/277V, FD-010-120V, FD-010-277V
Leviton	Leviton Centura Fluorescent Control System, IllumaTech™ IP7 Series, DPSPE-212
Lightolier	ZP600FAM120, MP1500FAM120, V2000FAMU
Lithonia	LEQ BC, LEQ LVBC, SLD LVBC, SQ1DC
Lutron	DTV, NTFTV
Synergy	ISD BC 120/277

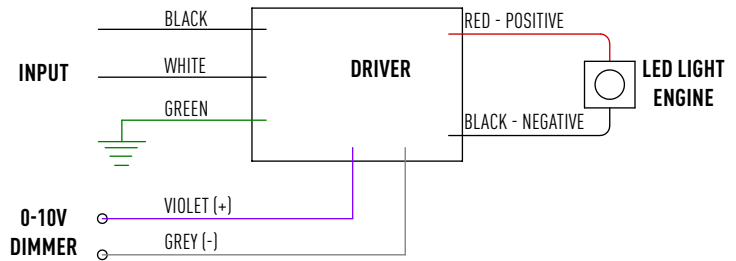

LUTRON ECOSYSTEM® DIMMING

- 120V or 277V
- Dims down to less than 1% or 5% light output
- Consult dimming manufacturer for installation instructions

COMPATIBLE DIMMERS

Product	Part Number(s)
EcoSystem	CS-1L-WM, CS-2L-WM, CS-1L-CM, CS-2L-CM, EcoSystem ESN, Grafik Eye QS with EcoSystem, Quantum

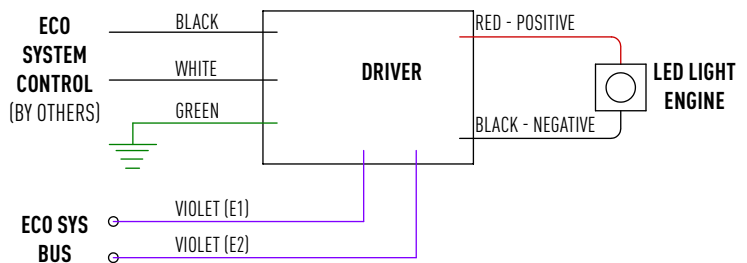

LUTRON HI-LUME® DIMMING

- 120V or 277V
- Dims down to less than 1% light output
- Consult dimming manufacturer for installation instructions

COMPATIBLE DIMMERS

Product	Part Number(s)
NovaT	NTF-10, NTF-103P, NTF-103P-277, NTF-10-277
Nova	NF-10, NF-103P, NF-103P-277, NF-10-277
Vareo	VF-10
Skylark	SF-10P, SF-12P-277, SF-12P-277-3, SF-103P
Diva	DVF-103, DVF-103P-277, DVSCF-103P, DVSCF-103P-277
Ariadni	AYF-103P, AYF-103P-277
Vierti	VTF-6AM
Maestro	MAF-6AM, MAF-6AM-277, MSCF-6AM, MCSF-6AM-277
Maestro Wireless	MRF2-F6AN-DV
Spacer System	SPSF-6A, SPSF-6A-277, SPSF-6AM, SPSF-6AM-277
Lyneo	LXF-103PL, LXF-103PL-277
Radio RA 2	RRD-F6AN-DV
HomeWorks QS	HQRD-F6AN-DV

