

4" Gravity Cylinder Remote Emergency Backup - Wall Mounted

⚠ WARNING

Risk of electrical shock. Disconnect power before servicing or installing luminaire.

⚠ WARNING

Risk of injury or damage. Luminaire will fail if not installed properly. Follow installation instructions.

⚠ WARNING

Risk of injury. Wear safety glasses and gloves during installation and servicing. Allow ample time to cool before handling.

IMPORTANT SAFETY INSTRUCTIONS

- Read all installation instructions before installing. It is important to save these instructions.
- **Only install and connect LED module with power disconnected at the circuit breaker. Hot plugging, or connecting the module with power on, could damage the LEDs and is not covered by warranty.**
- Observe and follow all label information and instructions regarding dry, damp and wet location listings, proper Intense LED module, warnings of installation near combustible materials and/or insulation.
- Be sure to connect ground wire to prevent electric shock or other potential hazards.
- The product must be installed in a manner consistent with the intended use and in compliance with the national electrical codes and local codes by a person familiar with the construction and operation of the product and the hazards involved.
- **WARNING: Use only Intense Lighting trims listed for use with this fixture. Use of trims other than those listed by Intense Lighting is a violation of N.E.C 110-3(B) and voids all warranties.**

MOUNTING BRACKET:

1. Attach universal mounting bracket to junction box using hardware supplied with junction box.

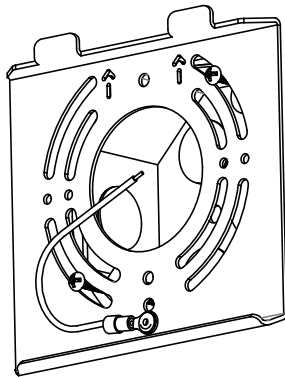

1

ELECTRICAL CONNECTIONS:

1. Make electrical connections through center hole of universal mounting bracket.
2. Connect ground wire from universal mounting bracket to green (ground) supply wire and ground wire from fixture, white wire from cylinder to white (neutral) supply wire and black wire from cylinder to black (hot) supply wire. Use UL listed connectors or wire nuts (by others) to make the connections. Connect dimming wires if applicable, see page 3.

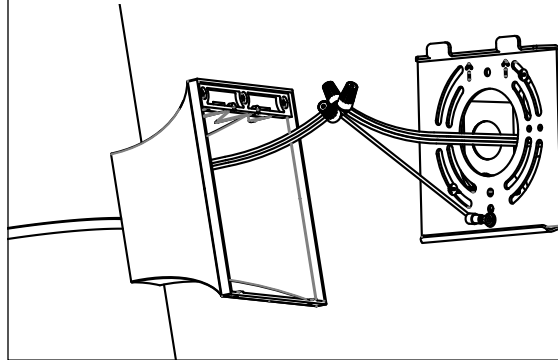

2

MOUNTING CYLINDER TO MOUNTING BRACKET:

1. Lift cylinder up and over mounting bracket. Align the arrows on the mounting bracket with the notches on the wall mount.

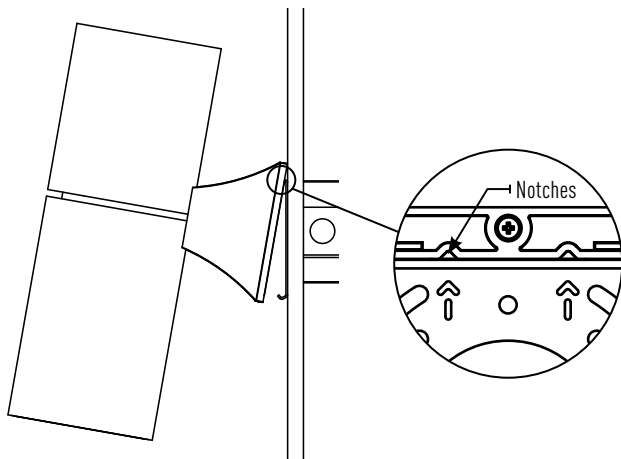

3

FASTEN SET SCREWS:

1. Attach the M3 slotted set screws under the wall mount with the hex key tool (do not overtighten).

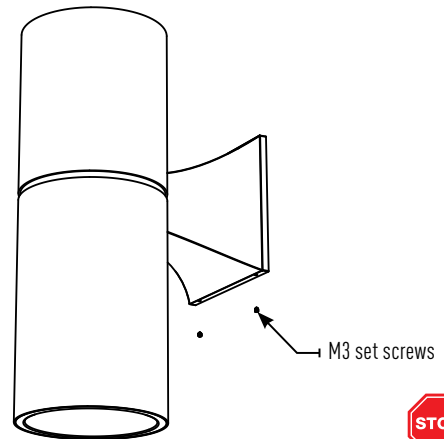

4

4" Gravity Cylinder Remote Emergency Backup - Wall Mounted

Remote Driver Housing Installation

REMOTE BOX INSTALLATION

1. Attach remote box at two 1/4" holes on 6 inch centers with frame in installation hardware (supplied by others)
2. Remove cover plate
3. Remove required knockouts and run conduit to junction box fixture is attached to (**maximum 50 feet length from fixture")
4. Run connecting wires for LED driver class 2 by local and national electrical regulations, minimum 18 AWG wire and at maximum 50 feet length
5. Make electrical connections (see wiring diagram at the end of this document)
6. Reinstall cover plate with supplied 8-32 hardware, insure wires are clear of box edges not pinched or damaged when cover is screwed down

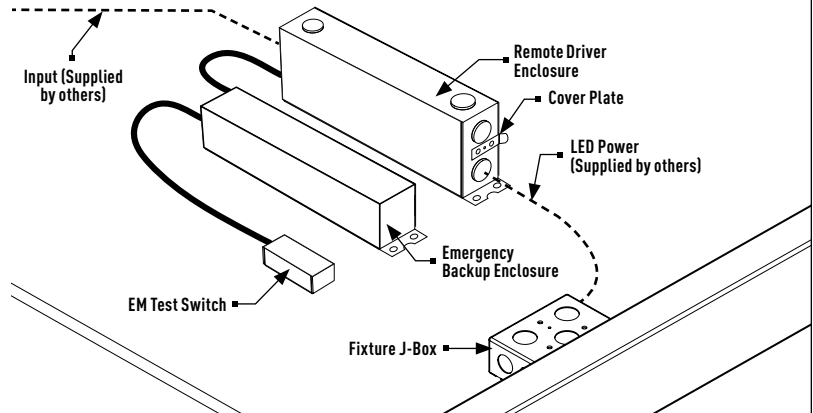

REPLACING OPTICS / INSTALLING ACCESSORIES:

1. Remove trim, then remove optic holder from cylinder.
2. Remove retaining ring that secures optic, then remove optic.
3. Install accessory in optic holder and/or insert new optic.
4. Secure retaining ring and replace optic holder then trim.

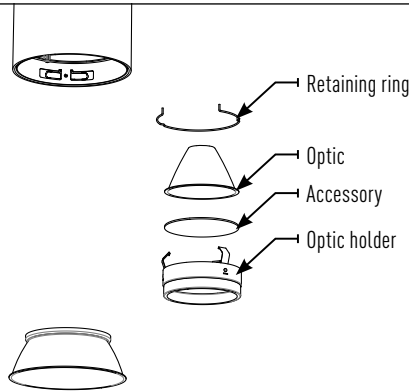

WIRING & DIMMING COMPATIBILITY

For use with all Intense Lighting product with supported dimming options.
Please check configuration of product for correct dimming protocol.

Phase Dimming or Lutron® LTEA2W Hi-Lume 2-Wire

- 120V Only
- Forward 1% / Reverse 5%

COMPATIBLE DIMMERS

Product	Part Number(s)	Type
Leviton	IPE04	Reverse
Leviton	IPI06-1LZ	Forward
Leviton	6633-P	Forward
Lutron	DVELV300P	Reverse
Lutron	DVCL-153P	Forward
Lutron	S600P	Forward
Cooper	DLC03P	Forward
Cooper	DAL06P	Forward

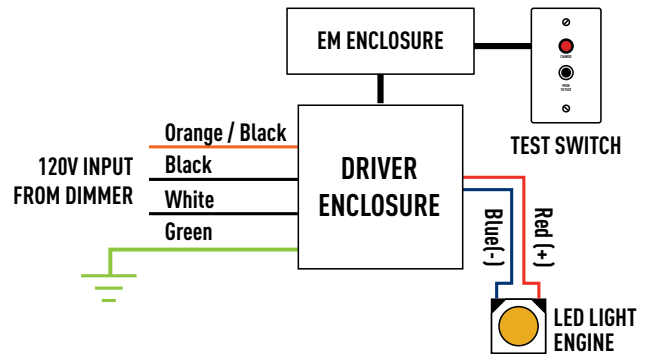

0-10V Dimming

- 120V or 277V
- Dims down to 1% or 0.1% light output
- Consult dimming manufacturer for installation instructions and power packs

COMPATIBLE DIMMERS

Manufacturer	Part Number(s)
HUNT	PS-010-IV-120V, PS-010-WH-120V, PS-010-3W-IV-120, PS-010-3W-WH-120V, PS-010-IV-277V, PS-010-WH-277V, PS-010-3W-IV-277V, PS-010-3W-WH-277V, FD-010: PS-IFC-010-IV, PS-IFC-010-WH-120/277V, FD-010: PS-IFC-010-3W-IV, PS-IFC-010-3W-WH-120/277V, FD-010-120V, FD-010-277V
Leviton	Leviton Centura Fluorescent Control System, IlLumaTech™ IP7 Series, DPSPE-212
Lightotier	ZP600FAM120, MP1500FAM120, V2000FAMU
Lithonia	LEQ BC, LEQ LVBC, SLD LVBC, SQ1DC
Lutron	DVTV, NTFTV
Synergy	ISD BC 120/277

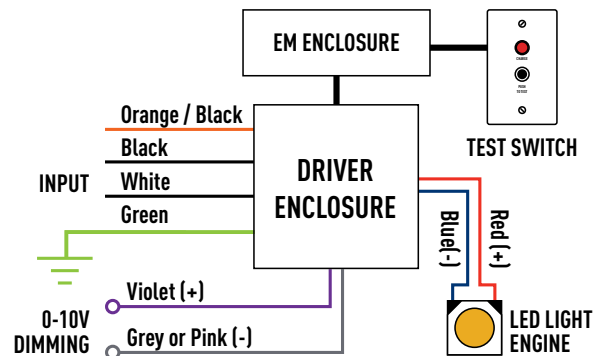

Lutron® LDE1 Hi-Lume EcoSystem

- 120V or 277V
- Dims down to 1%
- Consult dimming manufacturer for installation instructions

COMPATIBLE DIMMERS

Product	Part Number(s)
EcoSystem	CS-1L-WM, CS-2L-WM, CS-1L-CM, CS-2L-CM, EcoSystem ESN, Grafik Eye QS with EcoSystem, Quantum

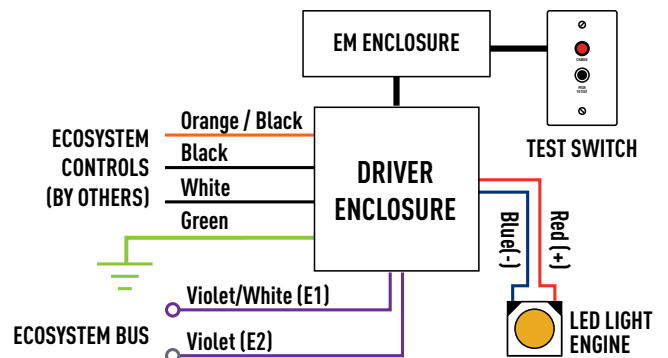

WIRING & DIMMING COMPATIBILITY

For use with all Intense Lighting product with supported dimming options.
Please check configuration of product for correct dimming protocol.

DMX512 RDM (Cylinders without RJ45)

- 120V or 277V
- Dims Down to 0.1% Light Output
- RDM Channel Programmable

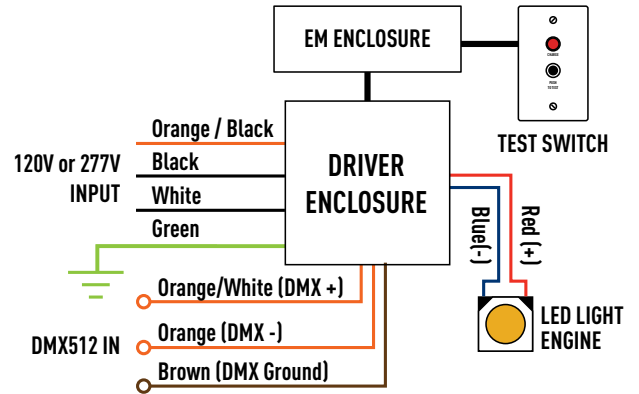

DALI

- 120V or 277V
- Dims down to 0.1%

