

⚠ WARNING

Risk of electrical shock. Disconnect power before servicing or installing luminaire.

⚠ WARNING

Risk of injury or damage. Luminaire will fail if not installed properly. Follow installation instructions.

⚠ WARNING

Risk of injury. Wear safety glasses and gloves during installation and servicing. Allow ample time to cool before handling.

IMPORTANT SAFETY INSTRUCTIONS

- Read all installation instructions before installing. It is important to save these instructions.
- Only install and connect LED module with power disconnected at the circuit breaker. Hot plugging, or connecting the module with power on, could damage the LEDs and is not covered by warranty.
- Observe and follow all label information and instructions regarding dry, damp and wet location listings, proper Intense LED module, warnings of installation near combustible materials and/or insulation.
- Be sure to connect ground wire to prevent electric shock or other potential hazards.
- The product must be installed in a manner consistent with the intended use and in compliance with the national electrical codes and local codes by a person familiar with the construction and operation of the product and the hazards involved.
- Do not block the trim aperture as this may cause unsafe operating conditions.
- **WARNING:** Use only Intense Lighting trims listed for use with this fixture. Use of trims other than those listed by Intense Lighting is a violation of N.E.C 110-3(B) and voids all warranties.

REMOTE BOX INSTALLATION

1. Attach remote box at two 1/4" holes on 6 inch centers with frame in installation hardware (supplied by others)
2. Remove cover plate

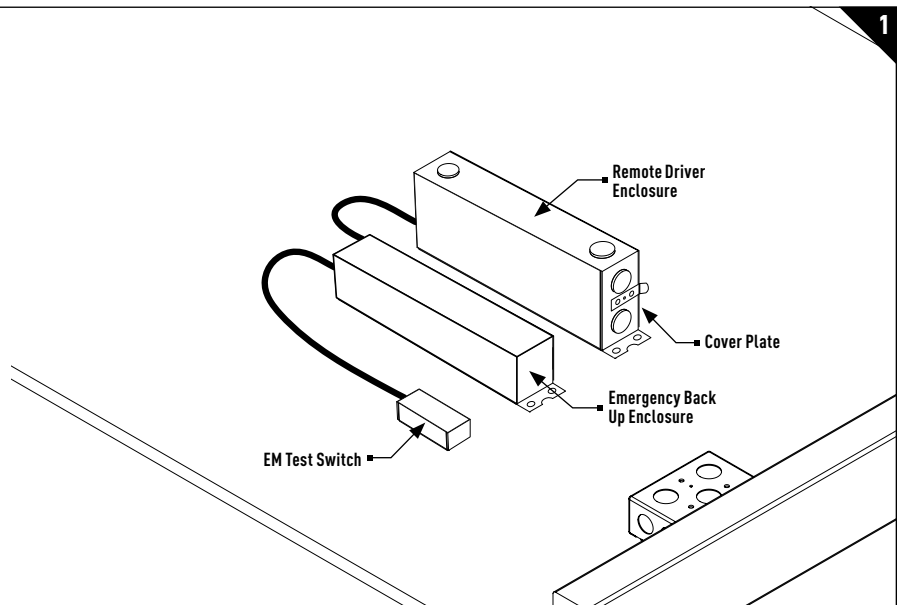

REMOTE BOX INSTALLATION

1. Remove required knockouts and run conduit to junction box fixture is attached to (**maximum 50 feet length from fixture*)
2. Run connecting wires for LED driver class 2 by local and national electrical regulations, minimum 18 awg wire and at maximum 50 feet length
3. Make electrical connections (See Page 2, Step 2)
4. Reinstall cover plate with supplied 8-32 hardware, insure wires are clear of box edges not pinched or damaged when cover is screwed down

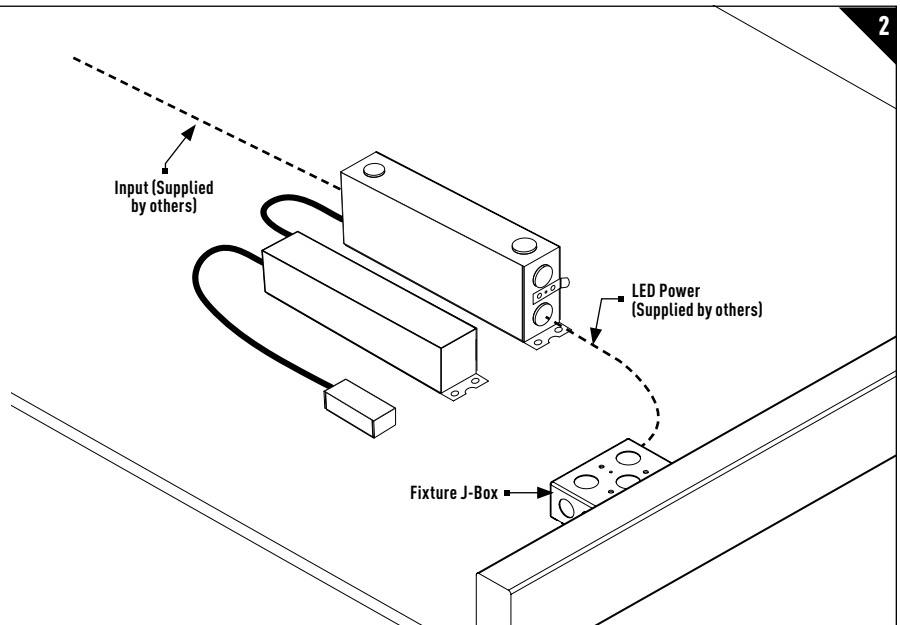

REMOVE LID AND DISCONNECT QUICK CONNECT:

3

1. Remove all three thumb screws.
2. Disconnect the quick connect from the driver and set lid assembly aside.

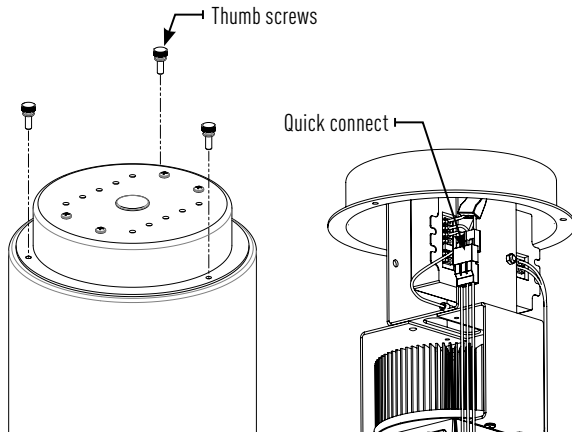

DISASSEMBLE WALL BRACKET AND MAKE ELECTRICAL CONNECTIONS:

4

1. Remove the two 5/16-18 nuts from the mounting plate inside cylinder. Set nuts and plate aside.
2. Run electrical connections through universal mounting bracket and make electrical connections inside junction box.
3. Connect ground wire from cylinder to green (ground) supply wire, black wire from cylinder to black (hot) supply wire and white wire from cylinder to white (neutral) supply wire. Use UL listed connectors or wire nuts (by others) to make the connections. Connect dimming wires if applicable, see page 4.

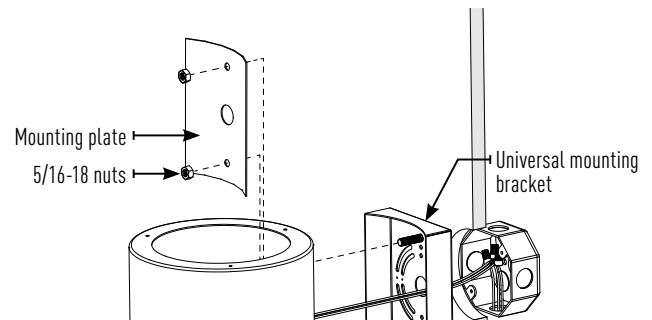

MOUNTING CYLINDER:

5

1. Attach universal mounting bracket to junction box using hardware supplied with junction box.
2. Mount cylinder over universal mounting bracket and replace mounting plate and 5/16" nuts inside cylinder.
3. Reconnect quick connect from the driver and replace the lid with all three thumb screws.

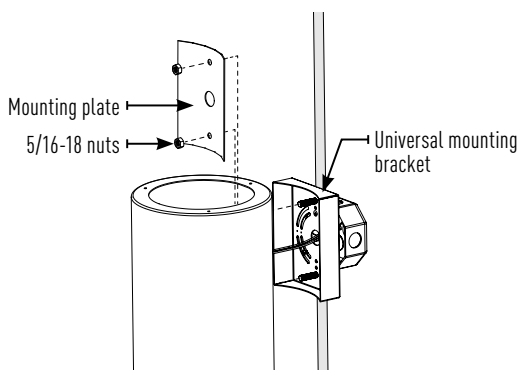

MAINTENANCE:

1. Remove all three thumb screws on the top of the cylinder and disconnect the quick connect from the driver.
2. Remove two 8-32 nuts from the driver plate and set aside.
3. Replace new driver on driver plate, see wiring diagram on page 3.

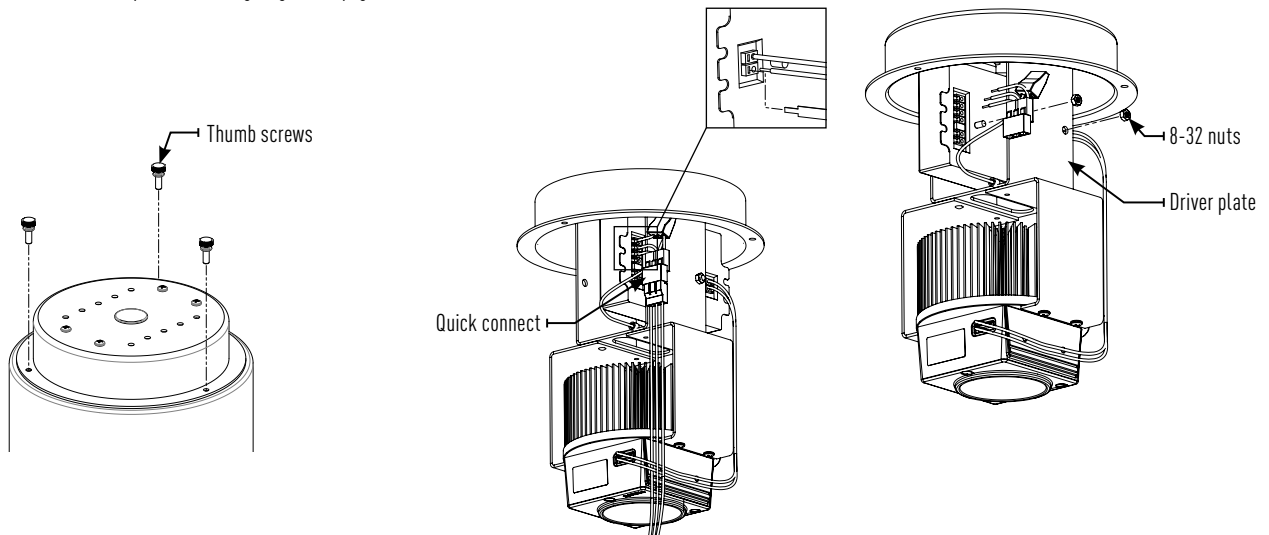

0-10V DIMMING (10% Dimming, eldoLED 1%, eldoLED 0.1%)

- 120V/277V
- Dims down to 10% light output
- Consult dimming manufacturer for installation instructions and power packs

COMPATIBLE DIMMERS

Manufacturer	Part Number(s)
HUNT	PS-010-IV-120V, PS-010-WH-120V, PS-010-3W-IV-120, PS-010-3W-WH-120V, PS-010-IV-277V, PS-010-WH-277V, PS-010-3W-IV-277V, PS-010-3W-WH-277V, FD-010: PS-IFC-010-IV, PS-IFC-010-WH-120/277V, FD-010: PS-IFC-010-3W-IV, PS-IFC-010-3W-WH-120/277V, FD-010-120V, FD-010-277V
Leviton	Leviton Centura Fluorescent Control System, IllumaTech™ IP7 Series, DPSPE-212
Lightolier	ZP600FAM120, MP1500FAM120, V2000FAMU
Lithonia	LEQ BC, LEQ LVBC, SLD LVBC, SQ1DC
Lutron	DTV, NTFTV
Synergy	ISD BC 120/277

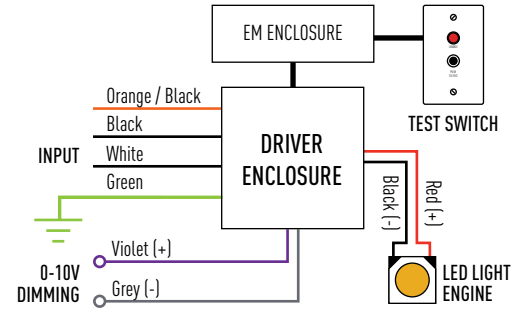

LUTRON ECOSYSTEM® DIMMING

- 120V or 277V
- Dims down to less than 1% or 5% light output
- Consult dimming manufacturer for installation instructions

COMPATIBLE DIMMERS

Product	Part Number(s)
EcoSystem	CS-1L-WM, CS-2L-WM, CS-1L-CM, CS-2L-CM, EcoSystem ESN, Grafik Eye QS with EcoSystem, Quantum

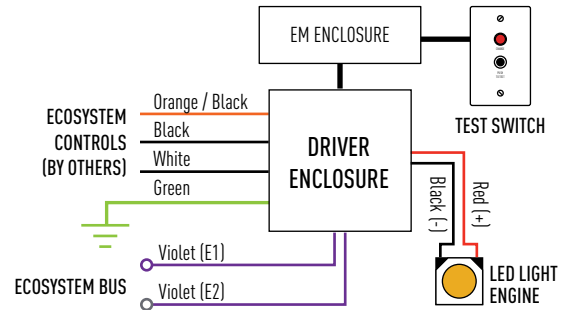

DMX512 RDM DIMMING

- 120V or 277V
- Dims down to 0.1% light output
- RDM channel programmable

