

# Installation Instructions

Gravity Gravity High Lumen Square Downlight (IHOL-6DS / IHOL-8DS)

IS-R1012R4

1 of 3

## IMPORTANT SAFETY INSTRUCTIONS

- Read all installation instructions before installing. It is important to save these instructions.
- Observe and follow all label information and instructions regarding dry, damp and wet location listings, proper Intense LED module, warnings of installation near combustible materials and/or insulation.
- Turn off power at circuit breaker before attempting to install or perform maintenance on the fixtures.
- Be sure to connect ground wire to prevent electric shock or other potential hazards.
- The product must be installed in a manner consistent with the intended use and in compliance with the national electrical codes and local codes.
- Do not block the trim aperture as this may cause unsafe operating conditions.
- **WARNING: RISK OF FIRE.** Non-IC fixture requires that insulation must be kept at least 3" away from all sides of the fixture. Minimum of 90°C supply conductors. Consult a qualified electrician before installation.

**WARNING:** Use only Intense Lighting trims listed for use with this fixture. Use of trims other than those listed by Intense Lighting is a violation of N.E.C 110-3(B) and voids all warranties.

## INSTALLATION INSTRUCTIONS

1. Install fixture into ceiling cavity using universal mounting bracket which has slot openings for C-Channel, flat bar, wood joist bar hanger (ordered separately) and 1/2" EMT (by others). Secure to joist or grid using fasteners or wire. C-Channel hangers are recommended for T-Bar ceilings, install with notches facing down to engage T-Bar grid (Fig. 1).
2. Mounting bracket includes a wing nut to adjust fixture to accommodate different ceiling thickness or ceiling construction (Fig. 2).
3. Remove junction box cover plate. Remove desired knockout, the junction box will accept metal conduit or non-metallic cable.
4. Connect black wire from fixture to black (**HOT**) supply wire, white wire from fixture to white (**NEUTRAL**) supply wire and connect the ground from fixture to green (**GROUND**) supply wire. Use UL listed connectors or wire nuts to make the connections (not included). (Fig. 3).
5. Make connections in junction box and replace cover plate.
6. Squeeze torsion springs on trim and insert into bracket in housing (Fig. 4).
7. Once all fixtures have been installed, power at the breaker can be restored.

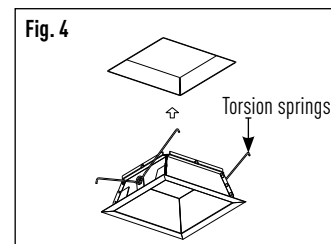
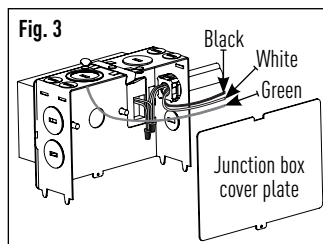
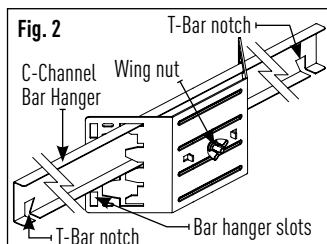
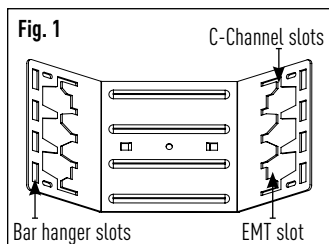

# WIRING & DIMMING COMPATIBILITY

For use with all Intense Lighting product with supported dimming options.  
Please check configuration of product for correct dimming protocol.

## Phase Dimming or Lutron® LTEA2W Hi-Lume 2-Wire

- 120V Only
- Forward 1% / Reverse 5%

### COMPATIBLE DIMMERS

Product	Part Number(s)	Type
Leviton	IPE04	Reverse
Leviton	IPI06-1LZ	Forward
Leviton	6633-P	Forward
Lutron	DVELV300P	Reverse
Lutron	DVCL-153P	Forward
Lutron	S600P	Forward
Cooper	DLC03P	Forward
Cooper	DAL06P	Forward

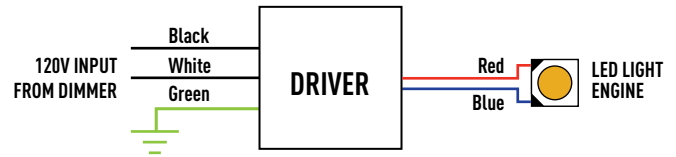

## 0-10V Dimming

- 120V or 277V
- Dims down to 1% or 0.1% light output
- Consult dimming manufacturer for installation instructions and power packs

### COMPATIBLE DIMMERS

Manufacturer	Part Number(s)
HUNT	PS-010-IV-120V, PS-010-WH-120V, PS-010-3W-IV-120, PS-010-3W-WH-120V, PS-010-IV-277V, PS-010-WH-277V, PS-010-3W-IV-277V, PS-010-3W-WH-277V, FD-010: PS-IFC-010-IV, PS-IFC-010-WH-120/277V, FD-010: PS-IFC-010-3W-IV, PS-IFC-010-3W-WH-120/277V, FD-010-120V, FD-010-277V
Leviton	Leviton Centura Fluorescent Control System, IlLumaTech™ IP7 Series, DPSPE-212
Lightotier	ZP600FAM120, MP1500FAM120, V2000FAMU
Lithonia	LEQ BC, LEQ LVBC, SLD LVBC, SQ1DC
Lutron	DVTV, NTFTV
Synergy	ISD BC 120/277

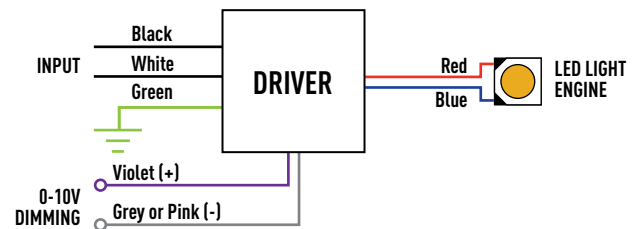

## Lutron® LDE1 Hi-Lume EcoSystem

- 120V or 277V
- Dims down to 1%
- Consult dimming manufacturer for installation instructions

### COMPATIBLE DIMMERS

Product	Part Number(s)
EcoSystem	CS-1L-WM, CS-2L-WM, CS-1L-CM, CS-2L-CM, EcoSystem ESN, Grafik Eye QS with EcoSystem, Quantum

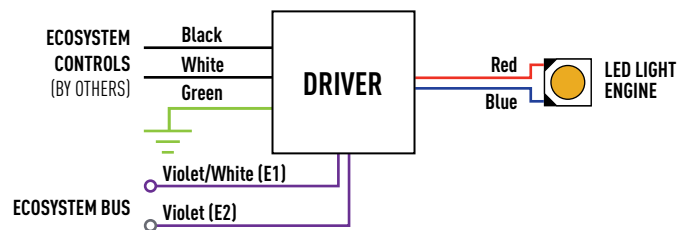

## DMX512 RDM (Downlights with RJ45)

- 120V or 277V
- Dims Down to 0.1% Light Output
- RDM Channel Programmable

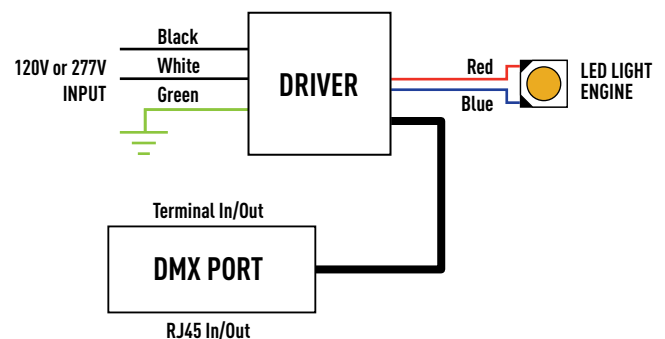

# WIRING & DIMMING COMPATIBILITY

For use with all Intense Lighting product with supported dimming options.  
Please check configuration of product for correct dimming protocol.

## DMX512 RDM (Cylinders without RJ45)

- 120V or 277V
- Dims Down to 0.1% Light Output
- RDM Channel Programmable

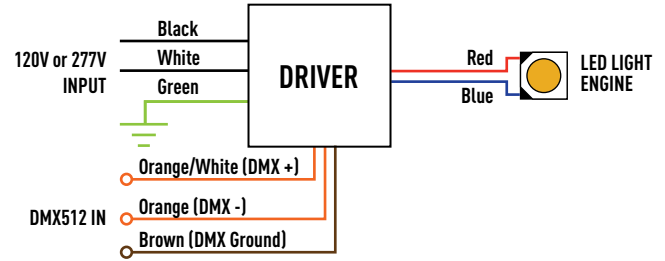

## 0-10V With Dynamic Beam

- 120V or 277V
- Dims down to 1% or 0.1% light output
- Consult dimming manufacturer for installation instructions and power packs

### COMPATIBLE DIMMERS

Manufacturer	Part Number(s)
HUNT	PS-010-IV-120V, PS-010-WH-120V, PS-010-3W-IV-120, PS-010-3W-WH-120V, PS-010-IV-277V, PS-010-WH-277V, PS-010-3W-IV-277V, PS-010-3W-WH-277V, FD-010: PS-IFC-010-IV, PS-IFC-010-WH-120/277V, FD-010: PS-IFC-010-3W-IV, PS-IFC-010-3W-WH-120/277V, FD-010-120V, FD-010-277V
Leviton	Leviton Centura Fluorescent Control System, IllumaTech™ IP7 Series, DPSPE-212
Lightolier	ZP600FAM120, MP1500FAM120, V2000FAMU
Lithonia	LEQ BC, LEQ LVBC, SLD LVBC, SQ1DC
Lutron	DVTV, NTFTV
Synergy	ISD BC 120/277

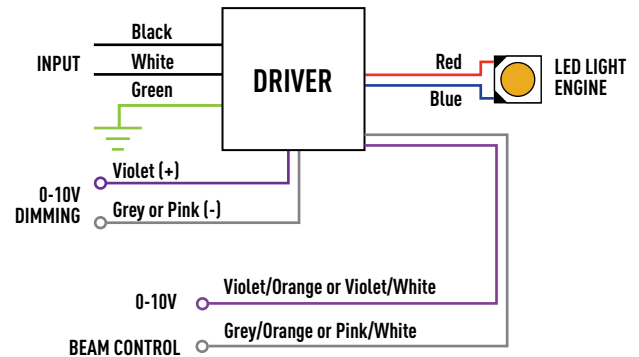

## 0-10V With Tunable White

- 120V or 277V
- Dims down to 1% or 0.1% light output
- Consult dimming manufacturer for installation instructions and power packs

### COMPATIBLE DIMMERS

Manufacturer	Part Number(s)
HUNT	PS-010-IV-120V, PS-010-WH-120V, PS-010-3W-IV-120, PS-010-3W-WH-120V, PS-010-IV-277V, PS-010-WH-277V, PS-010-3W-IV-277V, PS-010-3W-WH-277V, FD-010: PS-IFC-010-IV, PS-IFC-010-WH-120/277V, FD-010: PS-IFC-010-3W-IV, PS-IFC-010-3W-WH-120/277V, FD-010-120V, FD-010-277V
Leviton	Leviton Centura Fluorescent Control System, IllumaTech™ IP7 Series, DPSPE-212
Lightolier	ZP600FAM120, MP1500FAM120, V2000FAMU
Lithonia	LEQ BC, LEQ LVBC, SLD LVBC, SQ1DC
Lutron	DVTV, NTFTV
Synergy	ISD BC 120/277

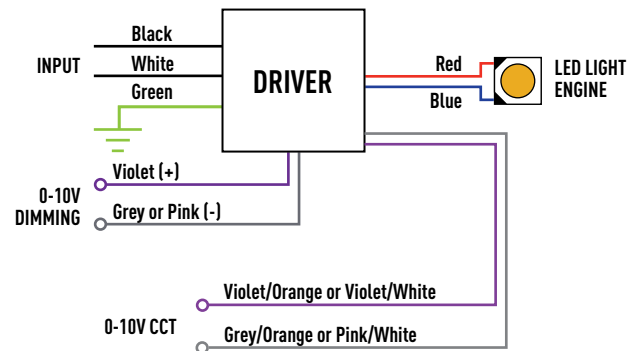

## DALI With Tunable White

- 120V or 277V
- Dims down to 0.1%

