

Installation Instructions

For Use With Gravity 2-inch New Construction IC-Rated Downlight & Adjustable (GD2DR, GD2DS, GD2AR & GD2AS)

⚠ WARNING

Risk of electrical shock. Disconnect power before servicing or installing luminaire.

⚠ WARNING

Risk of injury or damage. Luminaire will fail if not installed properly. Follow installation instructions.

⚠ WARNING

Risk of injury. Wear safety glasses and gloves during installation and servicing. Allow ample time to cool before handling.

IMPORTANT SAFETY INSTRUCTIONS

- Read all installation instructions before installing. It is important to save these instructions.
- Only install and connect LED module with power disconnected at the circuit breaker. Hot plugging, or connecting the module with power on, could damage the LEDs and is not covered by warranty.
- Connectors on modules and approved housing are keyed for specific voltage combinations; do not force or attempt to bypass connectors.
- Observe and follow all label information and instructions regarding dry, damp and wet location listings, proper Intense LED module, warnings of installation near combustible materials and/or insulation.
- Turn off power at circuit breaker before attempting to install or perform maintenance on the fixtures.
- Be sure to connect ground wire to prevent electric shock or other potential hazards.
- The product must be installed in a manner consistent with the intended use and in compliance with the national electrical codes and local codes by a person familiar with the construction and operation of the product and the hazards involved.
- Do not block the trim aperture as this may cause unsafe operating conditions.
- **WARNING: RISK OF FIRE.** Non-IC fixture requires that insulation must be kept at least 3" away from all sides of the fixture. Minimum of 90°C supply conductors. Consult a qualified electrician before installation.

WARNING: Use only Intense Lighting trims listed for use with this fixture. Use of trims other than those listed by Intense Lighting is a violation of N.E.C 110-3(B) and voids all warranties.

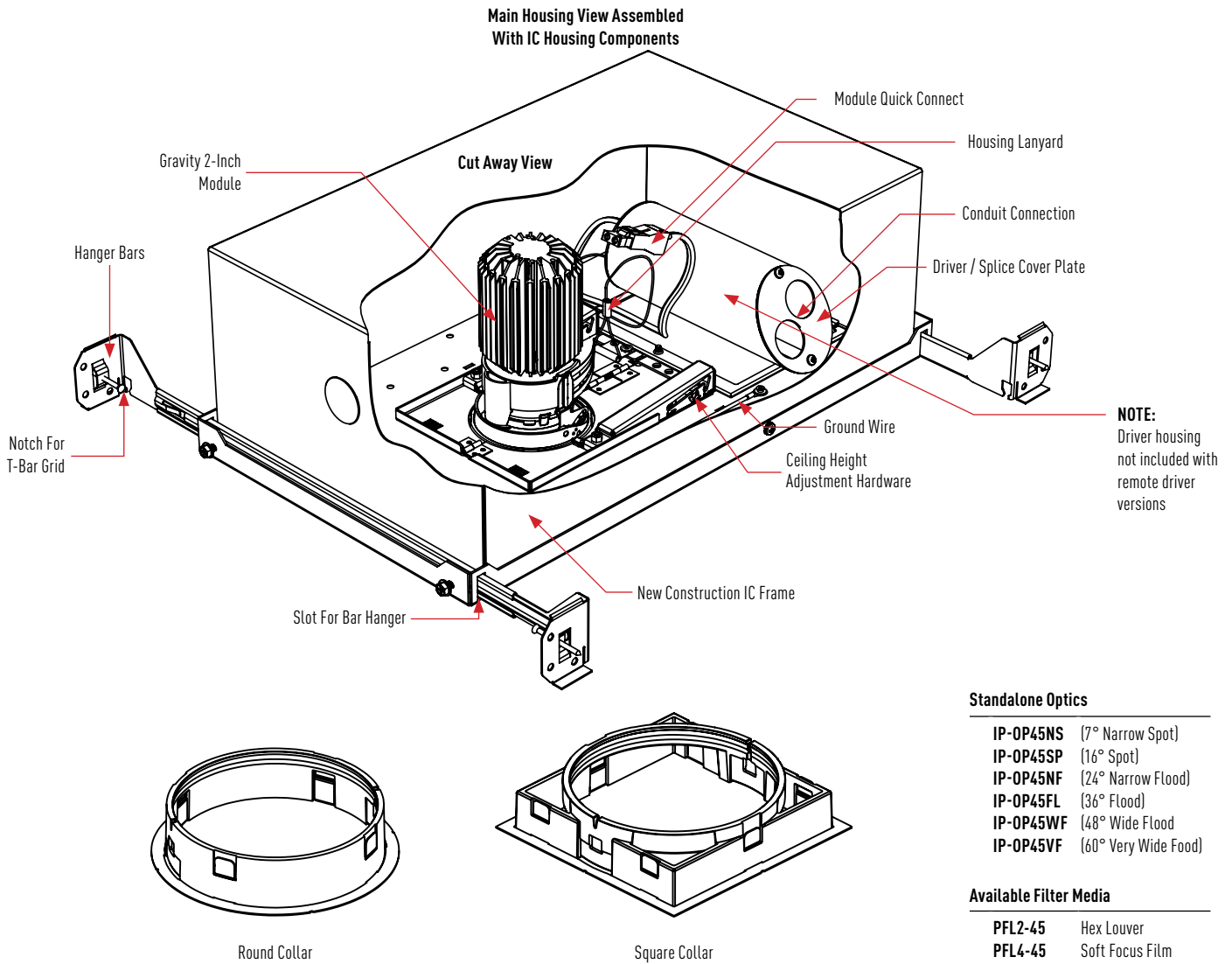

Installation Instructions

IS-R1088R4

2 of 11

For Use With Gravity 2-inch New Construction IC-Rated Downlight & Adjustable (GD2DR, GD2DS, GD2AR & GD2AS)

COLLAR HEIGHT SETTING:

Before installing frame into ceiling set tension to ceiling thickness as indicated
(Note: Ceiling adjustment hardware is NOT ACCESSIBLE BELOW CEILING because of small aperture size)

- 1/2" setting for single 1/2" sheet rock or laminated MDF (Fig. 1) (Note: 1/2" minimum ceiling thickness)
- 5/8" setting for single 5/8" sheet rock (Fig. 2) (Note: 5/8" maximum ceiling thickness)
- 1-1/4" setting for double 5/8" sheet rock (consult factory for thicker ceilings) (Fig. 3) (Note: 1-1/4" maximum ceiling thickness)

Ceiling Height Adjustment Settings

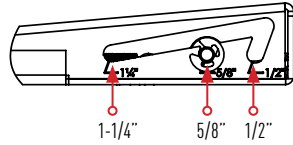

Ceiling Height Adjustment Hardware

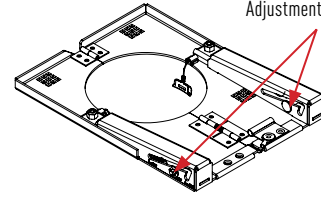

1

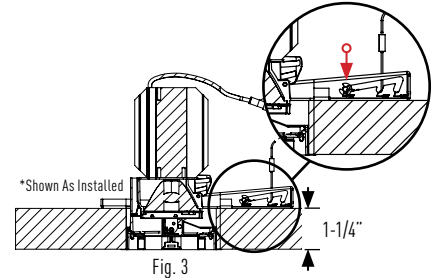
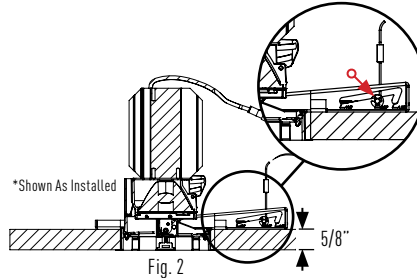
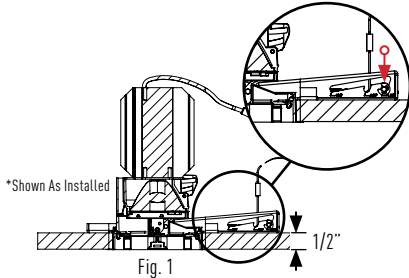

REMOVE COVER PLATE:

1. Remove (2) M3 pan head screws and junction box cover plate
2. Remove knockout on cover plate and attach flexible conduit or Romex® cable (Note: Use enough conduit to ensure that driver box can be pulled through ceiling aperture)
3. Connect new construction ground wire to driver / splice housing ground wire outside of housing
4. Make electrical connections
5. Insure conduit connection clamp does not interfere with cover sitting flush

Note: Do not remove factory wiring, only pull cover plate out far enough to make electrical connection to supplied power.

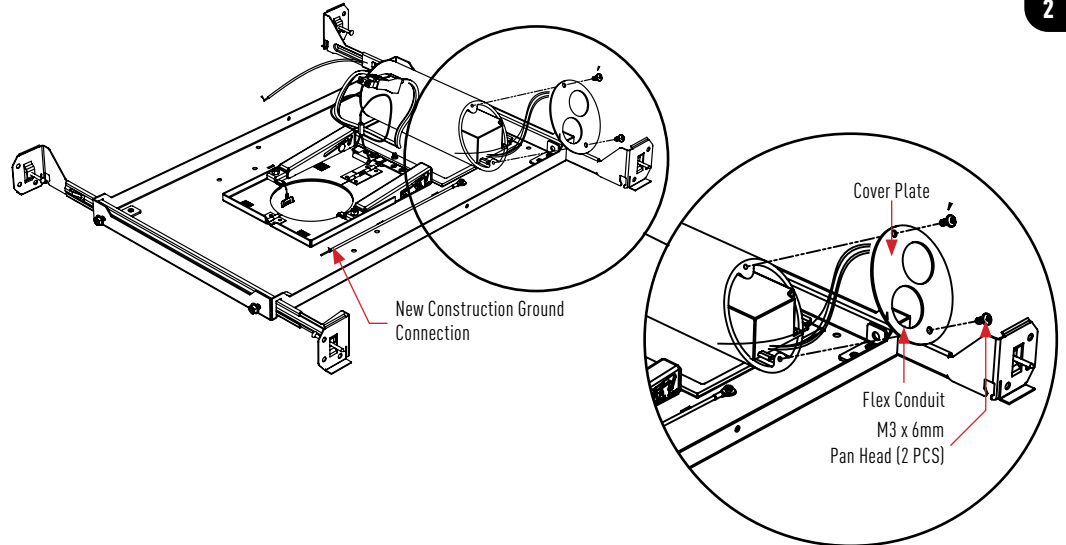

COLLAR INSTALLATION:

1. Run flex conduit from rigid to flex connection (provided by others) with flex conduit clamp (supplied by others) through IC housing with no less than 14" of flex inside of IC housing for service access
2. Make electrical connections
3. Place housing back onto ceiling frame
4. Attach housing cover with (2) 6-32 fasteners provided

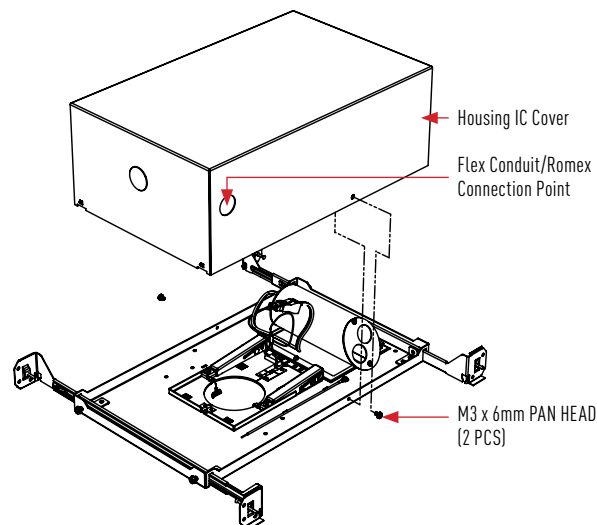

INSTRUCTIONS LHM-01062022 P-2

INTENSE LIGHTING | 3340 E La Palma Ave, Anaheim, CA 92806 | tel 714 630-9877 | fax 714 630-9883

For Intense Lighting's limited product warranty, go to www.intenselighting.com. For a printed copy of the warranty, you may call 800 961-5321.

© 2022 Intense Lighting, LLC. All rights reserved. Note: This document is subject to change without notice.

intense® | a LEVITON® company

Installation Instructions

IS-R1088R4

3 of 11

For Use With Gravity 2-inch New Construction IC-Rated Downlight & Adjustable (GD2DR, GD2DS, GD2AR & GD2AS)

4

COLLAR INSTALLATION:

1. Push blue attachment clips flush against ceiling. Align collar at blue attachment points with blue clips. (See Fig. 1)
2. Grip attachment clip and pull tension down below ceiling level and engage clip onto attachment point (Fig. 2)
3. Repeat step on other side of collar while holding collar in place
4. Collar should be flush against the ceiling and clip evenly placed in position (see detail)

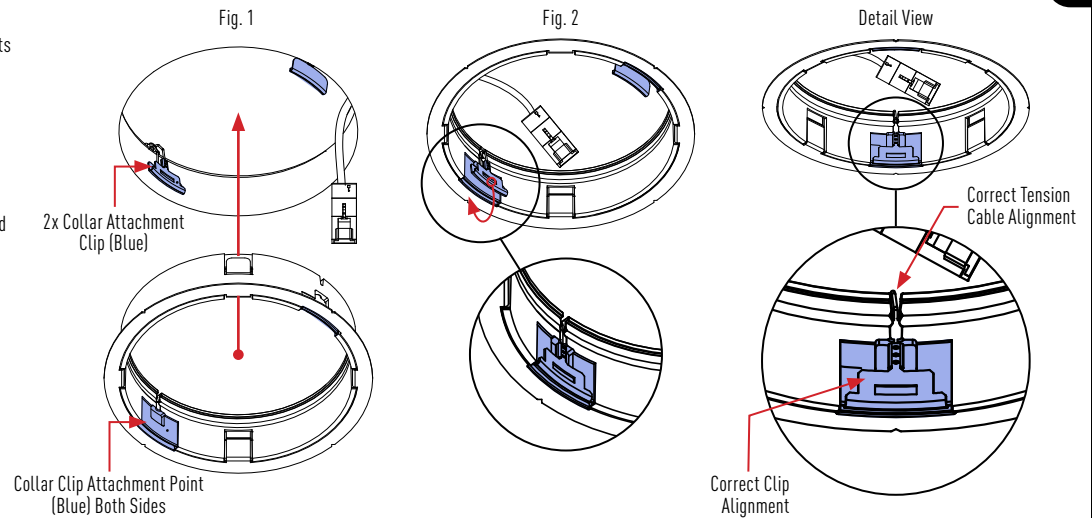

5

MODULE INSTALLATION:

1. Check that power is off at breaker, hot plugging may damage LEDs.
2. Install module at 0° angle
3. Connect female quick connect from housing to male quick connect on module, insure that the connector latch has snapped into place (Fig. 1)
4. While holding opposite sides evenly push module to snap into channel and confirm module sits parallel to ceiling line and is securely fastened into housing (Fig. 2)
5. Tighten set screws to secure module in place

NOTE: Must keep minimum of 8-inch of space BETWEEN LED module and driver housing

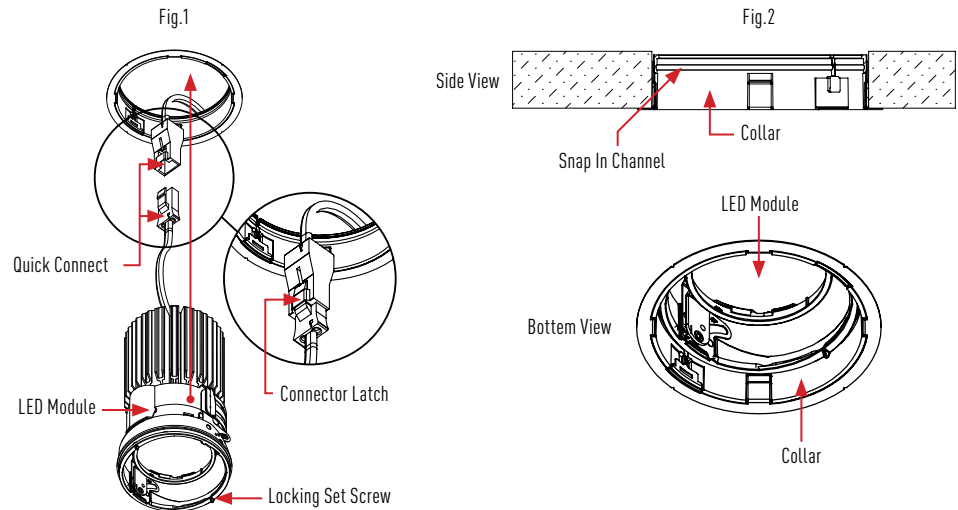

Installation Instructions

IS-R1088R4

4 of 11

For Use With Gravity 2-inch New Construction IC-Rated Downlight & Adjustable (GD2DR, GD2DS, GD2AR & GD2AS)

MODULE ADJUSTMENT (ADJUSTABLE MODULE ONLY):

Counter balanced fixture design allows for adjustment without use of fastening hardware. Precise offset center beam adjustment allows for maximum output with no cut off from downlight to 45° tilt positions (ceilings over 1-1/4" thick slightly reduce tilt adjustment.) Screwdriver can be used for hot aiming.

6A

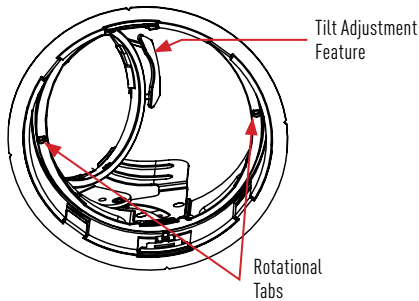

ROTATIONAL MODULE ADJUSTMENT:

1. Loosen set screw for rotational adjustments
2. Place thumb and index finger at rotational tabs and turn fixture to desired position
3. Leave fixture into desired position
4. Re-tighten set screw to set position

6B

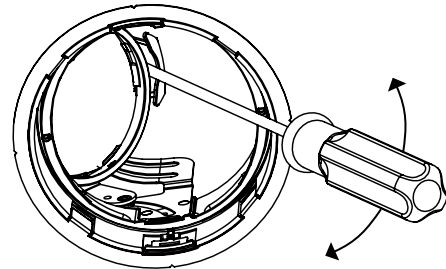

VERTICAL MODULE ADJUSTMENT (ADJUSTABLE MODULE ONLY):

1. Insert screwdriver into module adjustment feature, push module back towards desired position or pull forward to 0° for downlight position
2. Leave fixture into desired position

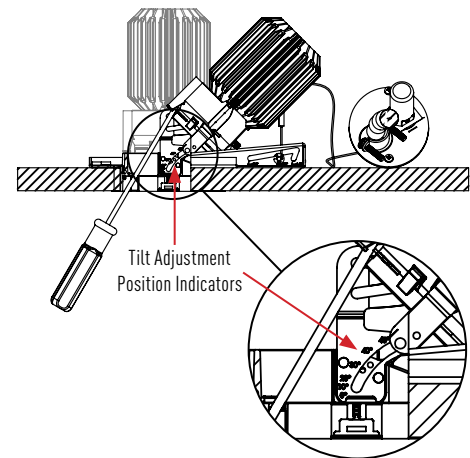
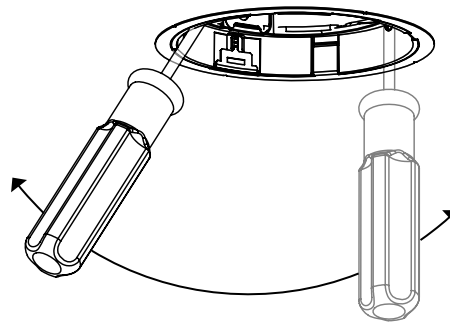

6C

TRIM INSTALLATION:

1. Position trim clips to collar attachment locations
2. Press trim against ceiling until flush with ceiling

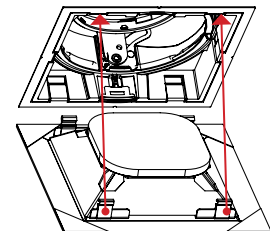
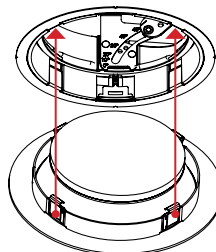
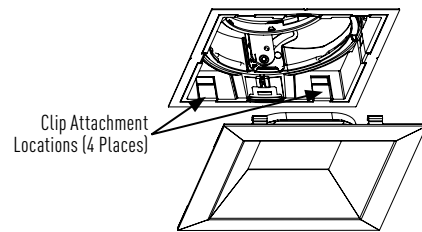
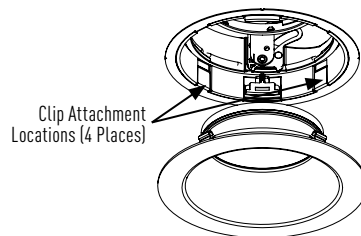

7

INSTRUCTIONS LHM-01062022 P-4

INTENSE LIGHTING | 3340 E La Palma Ave, Anaheim, CA 92806 | tel 714 630-9877 | fax 714 630-9883

For Intense Lighting's limited product warranty, go to www.intenselightning.com. For a printed copy of the warranty, you may call 800 961-5321.

© 2022 Intense Lighting, LLC. All rights reserved. Note: This document is subject to change without notice.

intense[®] | a LEVITON[®] company
LIGHTING

Installation Instructions

IS-R1088R4

5 of 11

For Use With Gravity 2-inch New Construction IC-Rated Downlight & Adjustable (GD2DR, GD2DS, GD2AR & GD2AS)

7

ACCESSORY INSTALLATION:

1. Remove LED module (See page 5, Section S1 & S2 for instructions)
2. Once LED module is removed, remove plastic cap from module assembly by gripping cap and pulling snaps away from module at slight angle (Fig. 1)
3. Install accessories into cap and press until snapped into place (Hex louver and film position interchangeable)
4. Reinstall plastic cap by aligning white dot towards center of tilt adjustment feature and snap flush against module
5. Reinstall LED module (See page 3, section 5 for instructions)

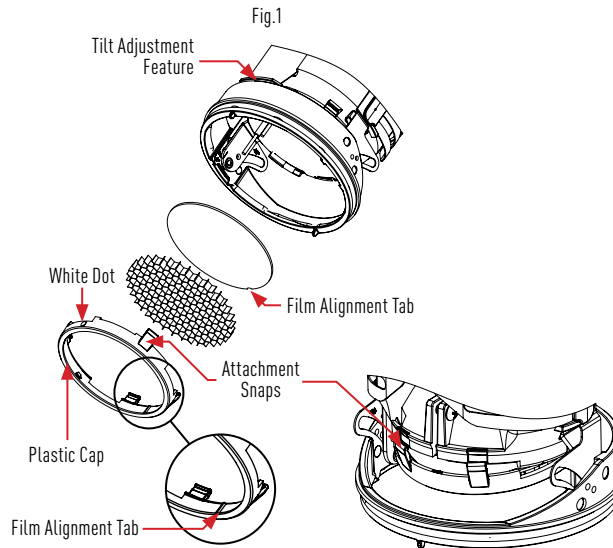

8

OPTIC REPLACEMENT:

1. Remove LED module (See page 5, Section S1 & S2 for instructions)
2. Once LED module is removed, remove plastic cap from module assembly by gripping cap and pulling snaps away from module at slight angle (Fig. 1)
3. To remove secondary optic, turn secondary optic tab slightly counter clockwise to remove from snap position (tip of screwdriver can be used against side of tab) (Fig. 2)
4. To install secondary optic, align triangle marks on optic and opening as shown on Fig. 2
5. Use protective paper shipped with film and press secondary optic against center of primary optic with finger, then turn tab clockwise until snaps into position
6. Reinstall plastic cap by aligning white dot towards center of tilt adjustment feature and snap flush against module
7. Reinstall LED module (See page 3, section 5 for instructions)

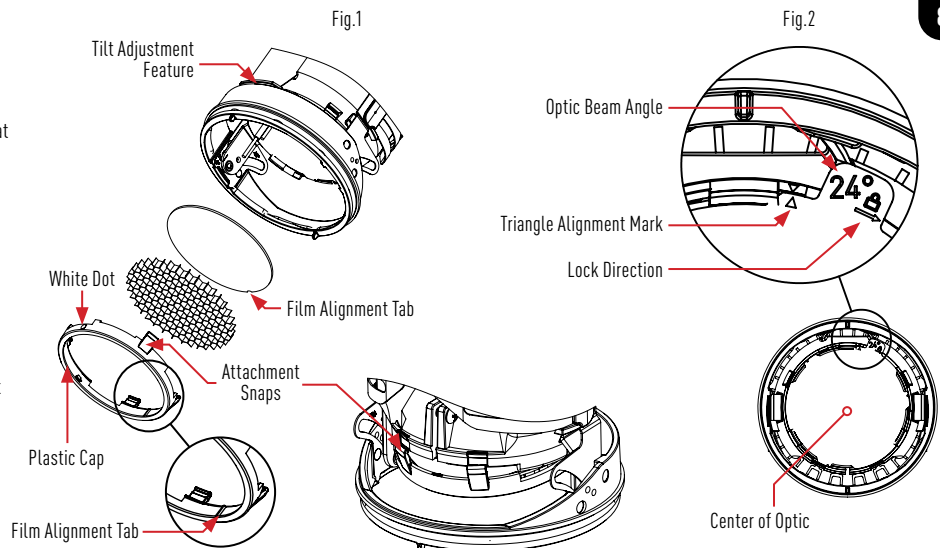

Installation Instructions

IS-R1088R4

6 of 11

For Use With Gravity 2-inch New Construction IC-Rated Downlight & Adjustable (GD2DR, GD2DS, GD2AR & GD2AS)

TRIMLESS INSTALLATION:

TRIMLESS MUD RING INSTALL:

1. Find the orientation features (blue clip location on mud ring) and align With the blue indicators on collar (Fig. 1)
2. Peel off backing on mud ring (Fig. 2)
3. Press the collar into the mud ring (Fig. 3)

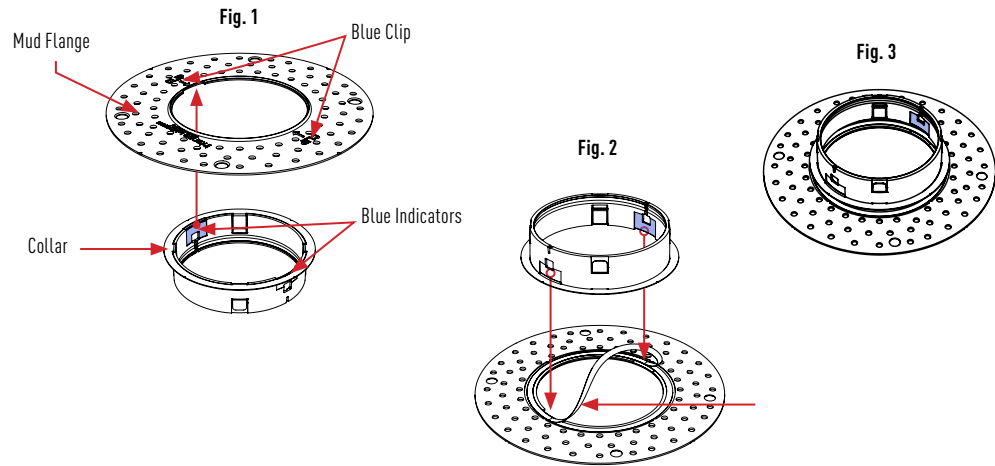

L1

TRIMLESS INSTALLATION

1. Align collar at blue attachment points with blue clips. Push collar flush against the ceiling (Fig. 1)
2. Grip attachment clip and pull tension down below ceiling and engage clip onto attachment point, push flush to ceiling (Fig. 2)
3. Repeat steps for other clip
4. Mud ring should be flush against the ceiling and the clip evenly placed in position
5. Secure perforated mud ring to housing using #6 drywall screws (supplied by others) (Fig. 3)
6. Insure mud flange is centered to fixture opening
7. Apply joint compound over perforated mud ring and feather out accordingly

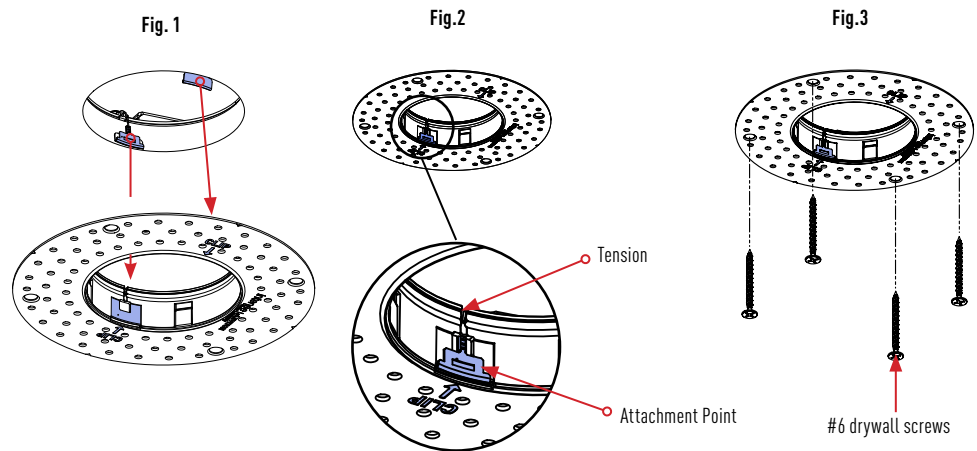

L2

Installation Instructions

IS-R1088R4

7 of 11

For Use With Gravity 2-inch New Construction IC-Rated Downlight & Adjustable (GD2DR, GD2DS, GD2AR & GD2AS)

LED MODULE & DRIVER SERVICING:

TRIM REMOVAL:

1. Remove trim from fixture by pulling trim out one side at a time.
2. To reinstall trim please see page 4, section 9

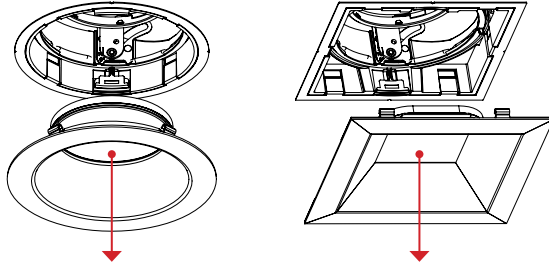

S1

LED MODULE REMOVAL:

1. Check that power is off at breaker, hot plugging may damage LEDs.
2. Adjust the LED module to 0° angle (See page 3, section 8 for details)
3. Pull module down to unsnap it from the collar channel
4. Disconnect quick connect from housing by pressing on the connector latch
5. To reinstall LED module please see page 3, section 5

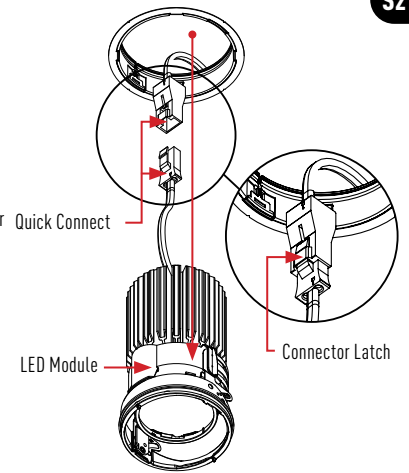

S2

DRIVER BOX REMOVAL:

1. Once LED Module is out of the way, locate the driver box and pull it through the ceiling opening.

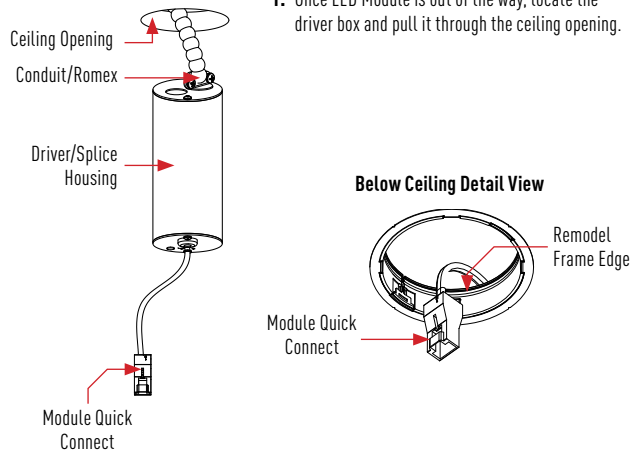

S3

DRIVER SERVICING:

1. Remove (2) M3 pan head screws and junction box cover plate
2. Make necessary maintenance and or replacement.
3. Make necessary wire connection, replace cover and tighten screws once completed
4. To reinstall driver box please see page 2, section 2

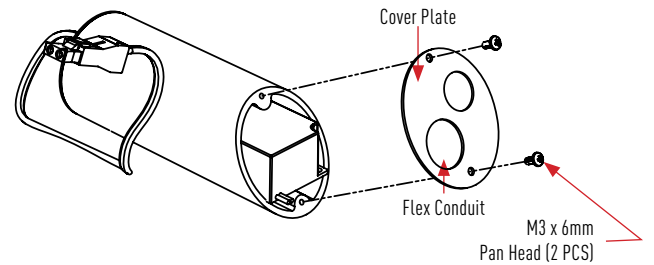

S4

COLLAR ATTACHMENT SERVICING

In the event of tension cable system failure consult factory for a replacement remodel frame in kit

1. Remove Trim (See page 6, section S1 for trim removal instructions)
2. Remove LED Module (See page 6, section S2 for LED Module removal instructions)
3. Pull Down Remodel Frame with Driver/Splice Housing (See page 6, section S3 for Driver/Splice Housing removal instructions)
4. Clip New Remodel Frame To existing Driver/Splice Housing using the existing frame attachment point.
5. Reinsert Driver/Splice Housing and old Remodel Frame into ceiling and Install new Remodel Frame. (See pages 2 -4 for fixture install instructions)

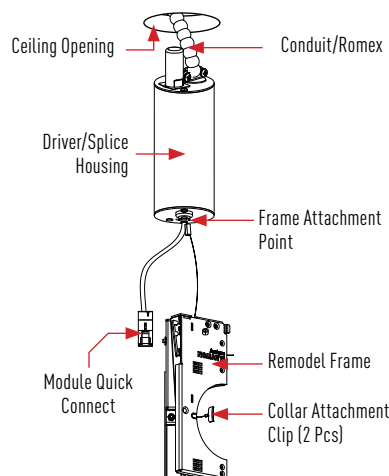

S5

INSTRUCTIONS LUM-01062022 P-7

INTENSE LIGHTING | 3340 E La Palma Ave, Anaheim, CA 92806 | tel 714 630-9877 | fax 714 630-9883

For Intense Lighting's limited product warranty, go to www.intenselight.com. For a printed copy of the warranty, you may call 800 961-5321.

© 2022 Intense Lighting, LLC. All rights reserved. Note: This document is subject to change without notice.

intense® | a LEVITON® company

Installation Instructions

IS-R1088R4

8 of 11

For Use With Gravity 2-inch New Construction IC-Rated Downlight & Adjustable (GD2DR, GD2DS, GD2AR & GD2AS)

REMOTE DRIVER OPTION

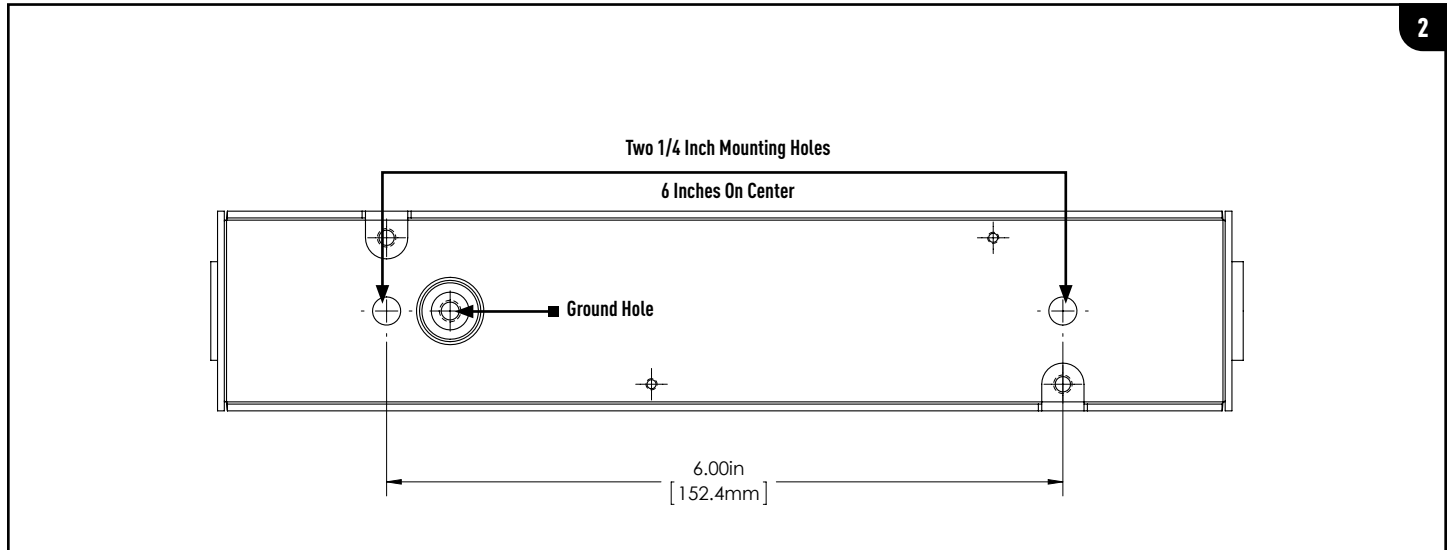

REMOTE BOX INSTALLATION

1. Remove two 8-32 fasteners and save to reinstall cover plate
2. Remove cover plate
3. Remove required knockouts and run conduit to junction box fixture is attached to (*maximum 50 feet length from fixture*)

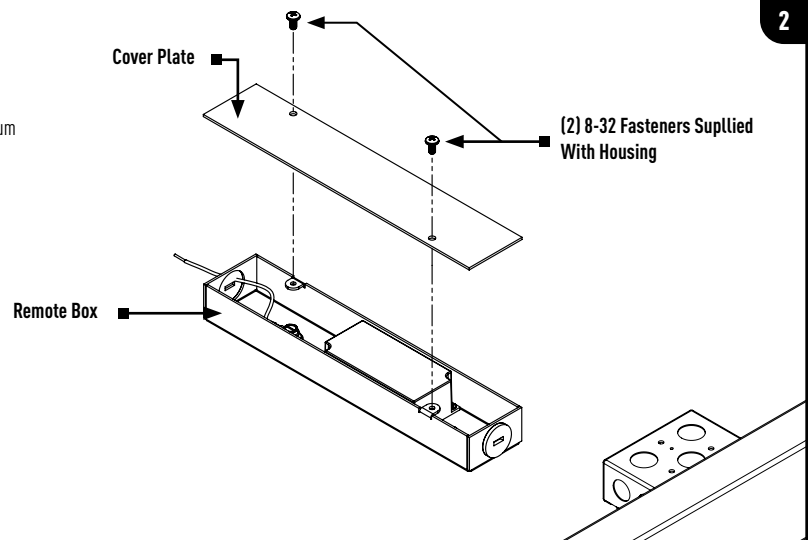

REMOTE BOX INSTALLATION

1. Run connecting wires for led driver class 2 by local and national electrical regulations, minimum 18 awg wire and at maximum 50 feet length
2. Attach remote box at two 1/4" holes on 6 inch centers with frame in installation hardware (supplied by others)
3. Make electrical connections (See Page 1, Section 1)
4. Reinstall cover plate with supplied 8-32 hardware, insure wires are clear of box edges not pinched or damaged when cover is screwed down

Note: *Not Rated For Through Wiring*

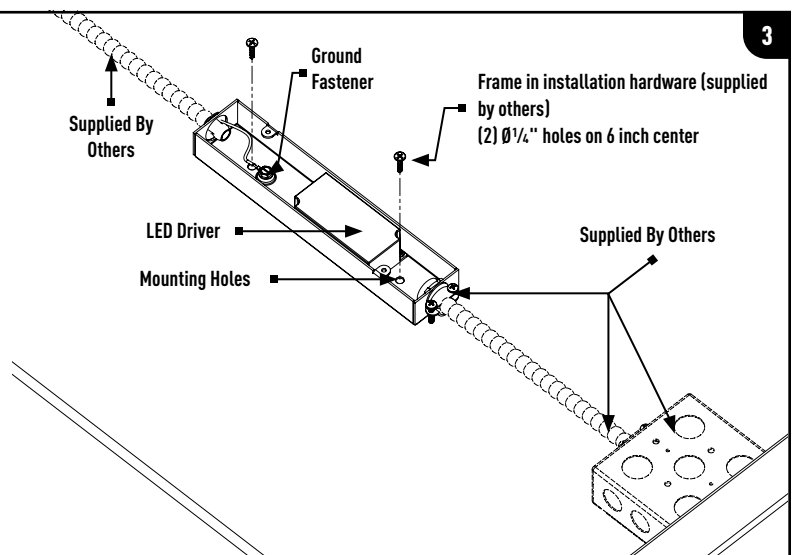

INSTRUCTIONS LHM-01062022 P-8

INTENSE LIGHTING | 3340 E La Palma Ave, Anaheim, CA 92806 | tel 714 630-9877 | fax 714 630-9883

For Intense Lighting's limited product warranty, go to www.intenselightning.com. For a printed copy of the warranty, you may call 800 961-5321.

© 2022 Intense Lighting, LLC. All rights reserved. Note: This document is subject to change without notice.

intense[®] | a LEVITON[®] company
LIGHTING

Installation Instructions

For Use With Gravity 2-inch New Construction IC-Rated Downlight & Adjustable (GD2DR, GD2DS, GD2AR & GD2AS)

WIRING DIAGRAM

4

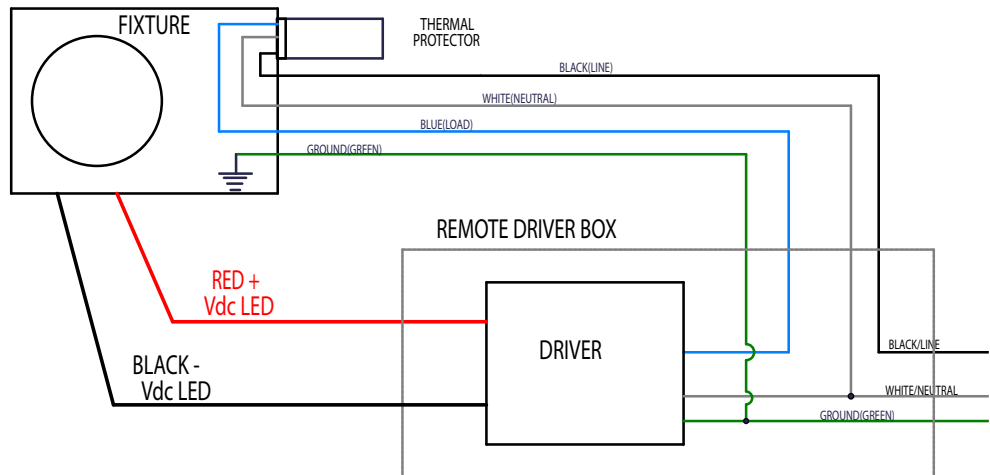

WIRING & DIMMING COMPATIBILITY

For use with all Intense Lighting product with supported dimming options.
Please check configuration of product for correct dimming protocol.

Phase Dimming or Lutron® LTEA2W Hi-Lume 2-Wire

- 120V Only
- Forward 1% / Reverse 5%

COMPATIBLE DIMMERS

Product	Part Number(s)	Type
Leviton	IPE04	Reverse
Leviton	IPI06-1LZ	Forward
Leviton	6633-P	Forward
Lutron	DVELV300P	Reverse
Lutron	DVCL-153P	Forward
Lutron	S600P	Forward
Cooper	DLC03P	Forward
Cooper	DAL06P	Forward

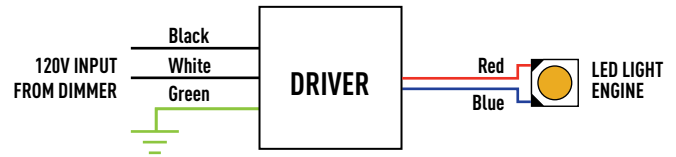

0-10V Dimming

- 120V or 277V
- Dims down to 1% or 0.1% light output
- Consult dimming manufacturer for installation instructions and power packs

COMPATIBLE DIMMERS

Manufacturer	Part Number(s)
HUNT	PS-010-IV-120V, PS-010-WH-120V, PS-010-3W-IV-120, PS-010-3W-WH-120V, PS-010-IV-277V, PS-010-WH-277V, PS-010-3W-IV-277V, PS-010-3W-WH-277V, FD-010: PS-IFC-010-IV, PS-IFC-010-WH-120/277V, FD-010: PS-IFC-010-3W-IV, PS-IFC-010-3W-WH-120/277V, FD-010-120V, FD-010-277V
Leviton	Leviton Centura Fluorescent Control System, IlLumaTech™ IP7 Series, DPSPE-212
Lightotier	ZP600FAM120, MP1500FAM120, V2000FAMU
Lithonia	LEQ BC, LEQ LVBC, SLD LVBC, SQ1DC
Lutron	DVTV, NTFTV
Synergy	ISD BC 120/277

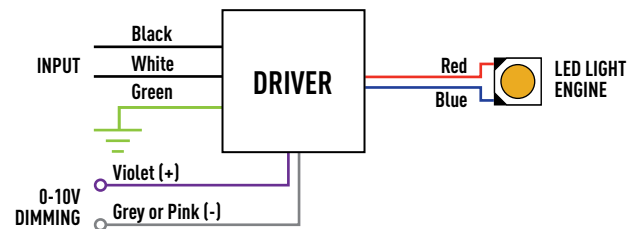

Lutron® LDE1 Hi-Lume EcoSystem

- 120V or 277V
- Dims down to 1%
- Consult dimming manufacturer for installation instructions

COMPATIBLE DIMMERS

Product	Part Number(s)
EcoSystem	CS-1L-WM, CS-2L-WM, CS-1L-CM, CS-2L-CM, EcoSystem ESN, Grafik Eye QS with EcoSystem, Quantum

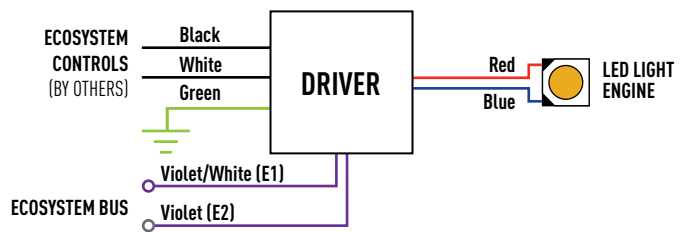

DMX512 RDM (Downlights with RJ45)

- 120V or 277V
- Dims Down to 0.1% Light Output
- RDM Channel Programmable

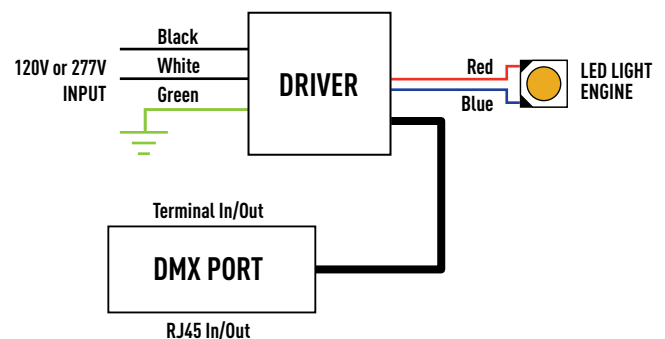

WIRING & DIMMING COMPATIBILITY

For use with all Intense Lighting product with supported dimming options.
Please check configuration of product for correct dimming protocol.

DMX512 RDM (Cylinders without RJ45)

- 120V or 277V
- Dims Down to 0.1% Light Output
- RDM Channel Programmable

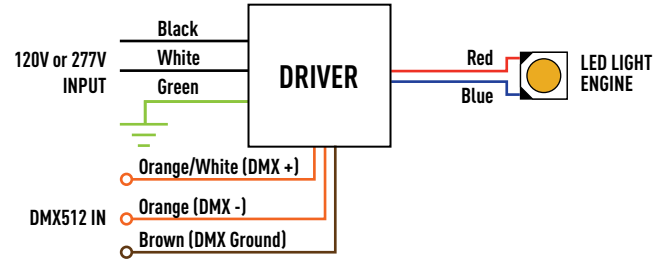

0-10V With Dynamic Beam

- 120V or 277V
- Dims down to 1% or 0.1% light output
- Consult dimming manufacturer for installation instructions and power packs

COMPATIBLE DIMMERS

Manufacturer	Part Number(s)
HUNT	PS-010-IV-120V, PS-010-WH-120V, PS-010-3W-IV-120, PS-010-3W-WH-120V, PS-010-IV-277V, PS-010-WH-277V, PS-010-3W-IV-277V, PS-010-3W-WH-277V, FD-010: PS-IFC-010-IV, PS-IFC-010-WH-120/277V, FD-010: PS-IFC-010-3W-IV, PS-IFC-010-3W-WH-120/277V, FD-010-120V, FD-010-277V
Leviton	Leviton Centura Fluorescent Control System, IllumaTech™ IP7 Series, DPSPE-212
Lightolier	ZP600FAM120, MP1500FAM120, V2000FAMU
Lithonia	LEQ BC, LEQ LVBC, SLD LVBC, SQ1DC
Lutron	DVTV, NTFTV
Synergy	ISD BC 120/277

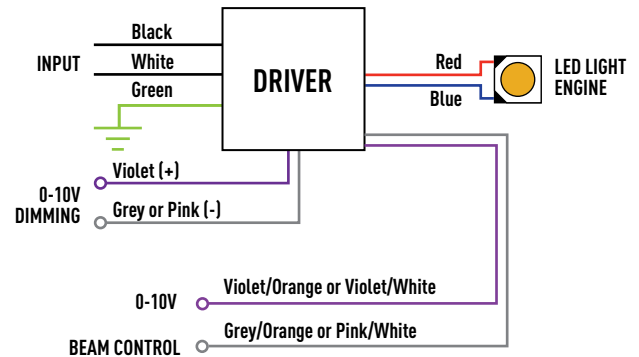

0-10V With Tunable White

- 120V or 277V
- Dims down to 1% or 0.1% light output
- Consult dimming manufacturer for installation instructions and power packs

COMPATIBLE DIMMERS

Manufacturer	Part Number(s)
HUNT	PS-010-IV-120V, PS-010-WH-120V, PS-010-3W-IV-120, PS-010-3W-WH-120V, PS-010-IV-277V, PS-010-WH-277V, PS-010-3W-IV-277V, PS-010-3W-WH-277V, FD-010: PS-IFC-010-IV, PS-IFC-010-WH-120/277V, FD-010: PS-IFC-010-3W-IV, PS-IFC-010-3W-WH-120/277V, FD-010-120V, FD-010-277V
Leviton	Leviton Centura Fluorescent Control System, IllumaTech™ IP7 Series, DPSPE-212
Lightolier	ZP600FAM120, MP1500FAM120, V2000FAMU
Lithonia	LEQ BC, LEQ LVBC, SLD LVBC, SQ1DC
Lutron	DVTV, NTFTV
Synergy	ISD BC 120/277

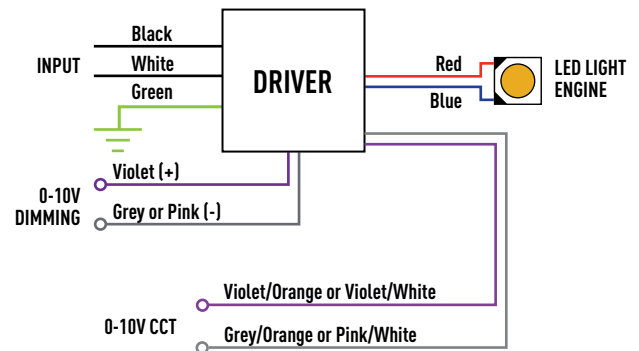

DALI With Tunable White

- 120V or 277V
- Dims down to 0.1%

