

# Instruction Sheet

For use with IQ & IQN

IS-T1014R3

1 of 1

## IMPORTANT SAFETY INSTRUCTIONS

- Read all installation instructions before installing. It is important to save these instructions.
- Turn off power at circuit breaker before attempting to install or perform maintenance on the fixtures.
- Wear rubber-soled shoes and work on a sturdy wooden ladder
- The product must be installed in a manner consistent with the intended use and in compliance with the national electrical codes and local codes.
- Ground fixture to avoid potential electrical shock.
- Do not install any fixture assembly closer than 6 inches from any curtain, or similiar combustibile material.
- **WARNING:** Lamp may be hot, allow lamp to cool before attempting to replace lamp (Do not use bar hand to replace lamp in fixture)
- **WARNING:** RISK OF FIRE. Minimum of 90°C supply conductors. Consult a qualified electrician before installation.

## REMOVING FIXTURE FROM TRACK

1. Turn power off.
2. Pull down the latch on the adapter and twist the adapter 1/4 turn.
3. Remove the fixture from the track.

## VERTICAL ADJUSTMENT AND LOCKING

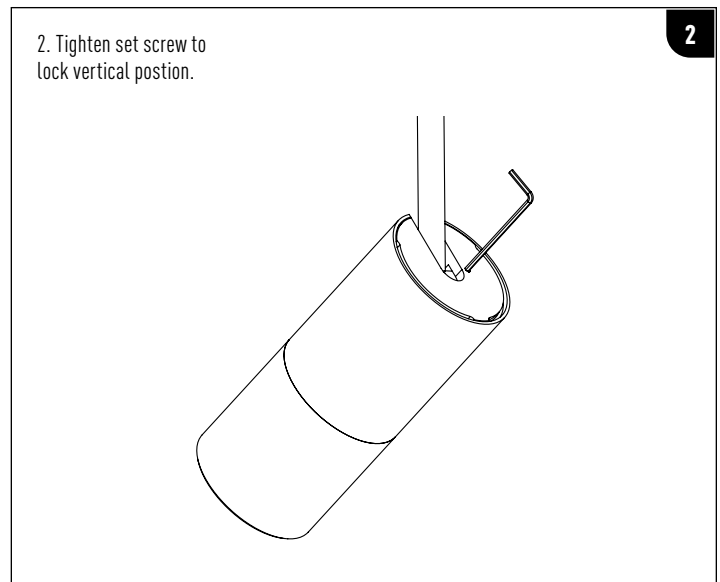
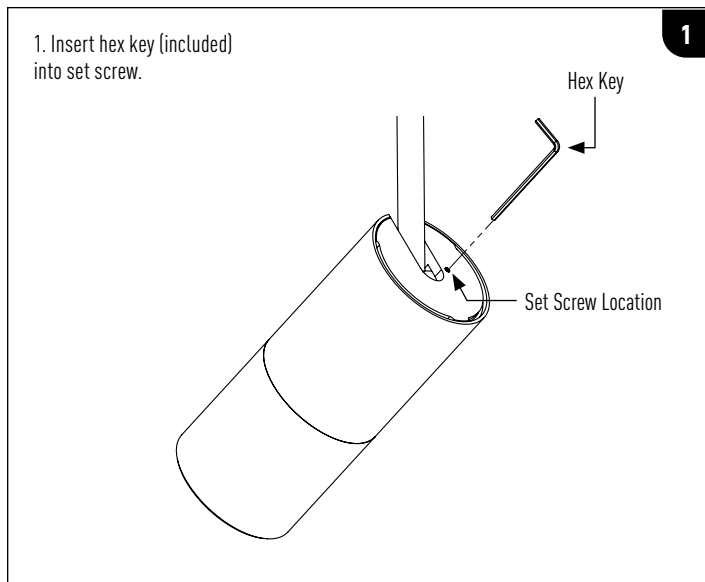

## OPTIC & MEDIA ACCESSORY

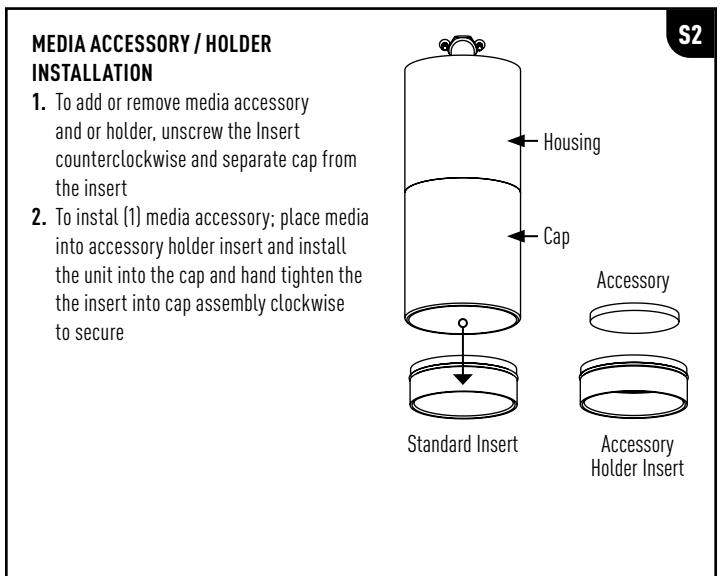
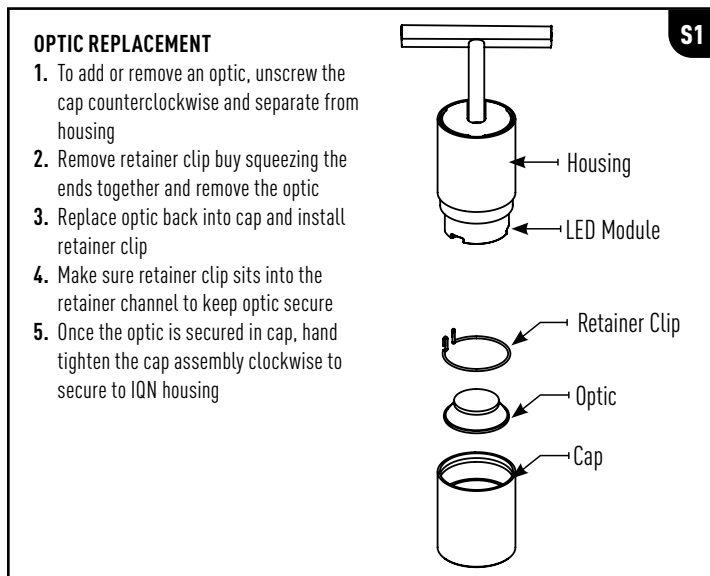

INSTRUCTIONS I/M-12062019 P-1

INTENSE LIGHTING | 3340 E La Palma Ave, Anaheim, CA 92806 | tel 714 630-9877 | fax 714 630-9883

For Intense Lighting's limited product warranty, go to [www.intenselighting.com](http://www.intenselighting.com). For a printed copy of the warranty, you may call 800 961-5321.

© 2019 Intense Lighting, LLC. All rights reserved. Note: This document is subject to change without notice.