

V-Rail Installation Instructions

IVR2-SPI: 2" Slim Post Integral Power Supply (Post Mounted)

IS-V1003R4

1 of 4



IMPORTANT: Read all instructions before starting installation. Keep instructions for future reference.

CAUTION: TO REDUCE RISK OF SHOCK, TURN OFF electrical supply BEFORE installing / SERVICING THE FIXTURES.

WARNING: LAMP WILL BE HOT. ALLOW LAMP TO COOL BEFORE ATTEMPTING TO REPLACE LAMP.

(Do Not Use Bare Hand To Replace Lamp In Fixture)

WARNING: Fixture must be installed in accordance of National Electrical Code (NEC) and/or any local codes.

Failure to do so may result in serious injury and/or damage to the fixture.

RECOMMEND TOOLS

- | | | | |
|-----------------|---------------------------------------|----------------------------|-------------------------------------|
| 1. Tape Measure | 4. Tube Bender | 7. Ratchet with Socket Set | 10. 2" Wide Painters Masking Tape |
| 2. Level | 5. Power Drill | 8. Allen Hex Set | 11. Scotch Brite Pad |
| 3. Cut-off Saw | 6. Half -Round File (To remove burrs) | 9. Silicone Sealant | 12. 3M Scotch Weld Epoxy (Or Equal) |

IMPORTANT SAFETY INSTRUCTIONS

SAFETY FOR LIGHTING

- Read all installation instructions before installing. It is important to save these instructions.
- V-Rail and electrical components must be grounded and connected to a GFCI as per local codes or the National Electrical Code.
- For LED lamp replacement, contact Intense Lighting at (800) 961-5321.
- Do not touch lens, guard, or enclosure.
- Keep lamp away from materials that may burn.
- WARNING - To reduce risk of FIRE OR INJURY.** Refer to V-Rail Maintenance instructions (#950004) to replace LED components. Do not operate the luminaire with a missing or damaged lens.
- "Use only with Class 2 power unit." Do not install the luminaire with other than a Class 2 power unit.
- Be sure to connect ground wire to prevent electric shock or other potential hazards.
- The product must be installed in a manner consistent with the intended use and in compliance with the national electrical codes and local codes.
- WARNING: RISK OF FIRE.** Most dwellings built before 1985 have supply wire rated for 60°C. Consult a qualified electrician before installation.

SAFETY FOR RAIL

- Always use protective gear such as breathing mask, goggles, and gloves. Refer to protective gear supplied with all tools power equipment, (such as cutoff saws) before installing V-Rail components.
- Check and be aware of all local railing code requirements.
- A structural analysis may be required per local codes. Responsibility for structural analysis is by others Intense Lighting's approved structural analysis calculations are available by request. Intense Lighting's strength calculations cannot be used per site specific locations. The calculations are intended for reference only to convey V-Rail strength parameters.

PROPERTY PLANNING

- Before commencing installation, check to make sure all parts arrived and are inspected. Notify Intense Lighting's Customer Service Department for all shipment questions.
- It is advised to lay the parts down on a clean padded surface (such as cardboard) to protect the V-Rail finish. Keep protective plastic over lighting section during installation by taping the ends.
- Verify electrical input voltage on site matches V-Rail requirements of 120V through 277V input.
- The spacing between posts with the V-Rail light can vary between 2 feet minimum center-to-center of posts to a maximum length of 5 feet center-to-center of posts. Do not exceed 5 foot spacing unless approved by a qualified licensed structural engineer. (Consult Intense Lighting)
- Depended on project. Shop drawings provided (by others or Intense Lighting) will aid in installation. V-Rail is a modular system, the installation instructions below only pertain to the parts supplied by Intense Lighting to be installed by qualified professional installer and licensed electricians. An electrical plan for the post need to be determined before installation of V-Rail.
- The anchors for base mounting are supplied by others. Responsibility of strength and selection for anchors are by others. Approvals may be required per local codes.
- It is very important to pre-plan the placements of the electrical stub-outs. Stub-out locations are determined by Intense Lighting and project Architect or Electrical Contractor. For new construction, accuracy of the dimensions regarding stairways (especially the rise) will benefit the ease of the V-Rail installation.

INSTALLATION

PRE-INSTALLATION FOR POST MOUNTED POST

(IT IS BEST TO MOCK UP THE V-RAIL COMPONENTS AT THE PROJECT SITE TO INSURE PROPER FIT. FOLLOW THESE INSTRUCTIONS IN THE ORDER PRESENTED.)

1. Place post over the electrical conduit stub out. Place the next post in line. **Important Note:** Horizontal distance between posts must be between 2'0" min. / 5'0" max. from center-to-center of posts (See drawing for important dimensions).
2. With posts in position, mark anchor bolt hole locations using the base template (supplied by Intense Lighting). Move V-Rail assemblies to a protected (safe) location near install.
3. Post must be plumbed. The base **MUST** mate to a level surface. It is recommended to shim and add a minimum amount of grout to achieve level before drilling anchor holes. Use post base or anchor bolt template to mark location. The Base Level Line must be orientated with all other post in series. Drill for anchors (supplied by others and approved per site conditions).
4. To determine the exact length of extension tubes, follow these instructions: With posts standing plumb, take a measurement between post center-lines to be referred to as dimension "V" for calculations required as follows. Dimension "V" minus the light section (which are offered from the factory as 21.75", 31.75", or 41.75" long) = total distance less light section divided by 2 = length of each "extension tube" (ex. 60" - 41.75" - 3.25" = 15" ÷ 2 = 7.5". For each extension tube length) cut "extension tubes" (per cutting instructions). Tape the extensions on to the ends of the lighted section and then onto the post swivel coupling to check fit. Place assembly into expected mounting positions with electricity **OFF**. Run wires as required. Make wiring connections red to red (24V positive) and blue to blue (24V negative) with supplied waterproof wire nuts. Making sure wires are safe from being pinched or cut. Make sure wiring seal grommet is tightly secured into each end of swivel. Continue with above instructions with other V-Rail sections.
5. With electricity **OFF**, install Intense Lighting LED driver / power supply enclosure as required per project. Connect incoming wires as follows: green to green (ground), white to white (neutral), black to black (line voltage) with UL recognized wire nuts supplied by Intense Lighting. Turn on electricity and check all LED operation. turn electricity **OFF** to troubleshoot any loose connections and check for correct polarity. Replace power supply enclosure cover if operation is successful.
6. Add fittings (by Intense Lighting or by fabricators) per fittings installation instructions before installing the next V-Rail lighted section.

NOTE: Refer to instruction sheets supplied with optional equipment, such as "battery back-up" or "proximity sensor/photocell" or dimming. All V-Rail instruction sheets are available by calling Intense Lighting at (800) 961-5321 or email at customerservice@intenselighting.com.

FINAL INSTALLATION FOR POST MOUNTED POST

NOTE: EPOXY WELD IS A PERMANENT BONDING OF PARTS. INSTALLER IS RESPONSIBLE FOR FINAL ASSEMBLY AND MUST BE SATISFIED WITH MOCK UP ASSEMBLY. CURE TIME OF EPOXY VARIES WITH DIFFERENT BRANDS AND TEMPERATURES.

1. Remove taped extension tubes from lighted section and swivel couplings. Install the first post and secure with anchor bolts (by others).
2. With a second person to hold the V-Rail lighted section. Epoxy weld extension tube #1 (per epoxy weld instructions) onto swivel coupling. Epoxy weld the V-Rail lighted section next. With extension tube #2 taped in place with second post, check fit and alignment with anchor bolts. Double check extension tube measurement. If position has changed, shorten tube or cut another tube if needed to accommodate a perfect fit. Epoxy weld extension tube #2 to V-Rail lighted section and tape joint. Epoxy weld swivel coupling with post attached anchor post in place. Repeat above procedures for remaining assemblies.
3. Add fittings (by Intense or by fabricators) per fittings installation instructions before installing the next V-Rail lighted section.
4. Finish V-Rail installation by attaching the end returns per installation instructions supplied for fittings.
5. Refer to V-Rail maintenance instructions for guidelines to maintain all finishes offered, or replacing LED components.

NOTE: All V-Rail instruction sheets are available by calling Intense Lighting at (800) 961-5321 or email at customerservice@intenselighting.com.

V-Rail Installation Instructions

IVR2-SPI: 2" Slim Post Integral Power Supply (Post Mounted)

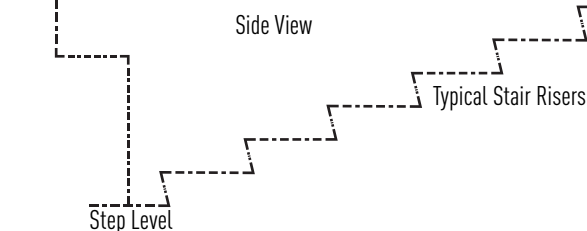
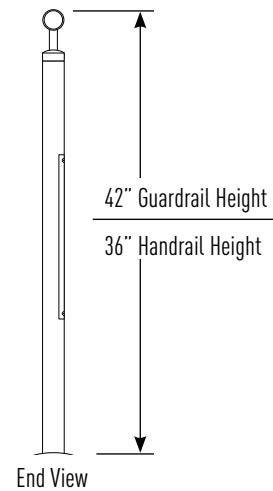
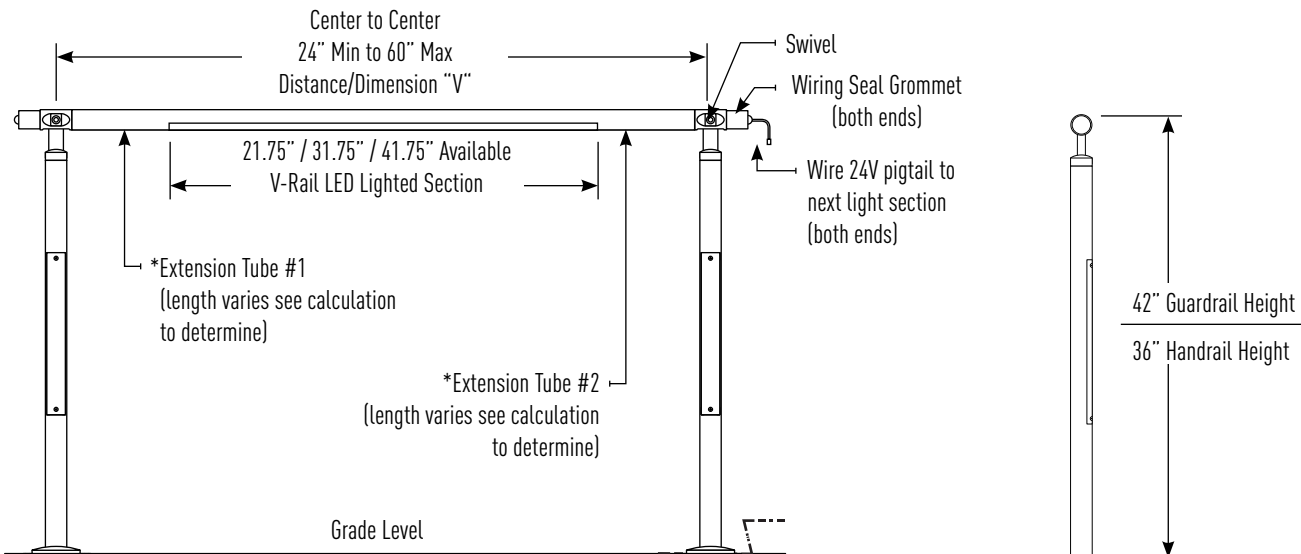
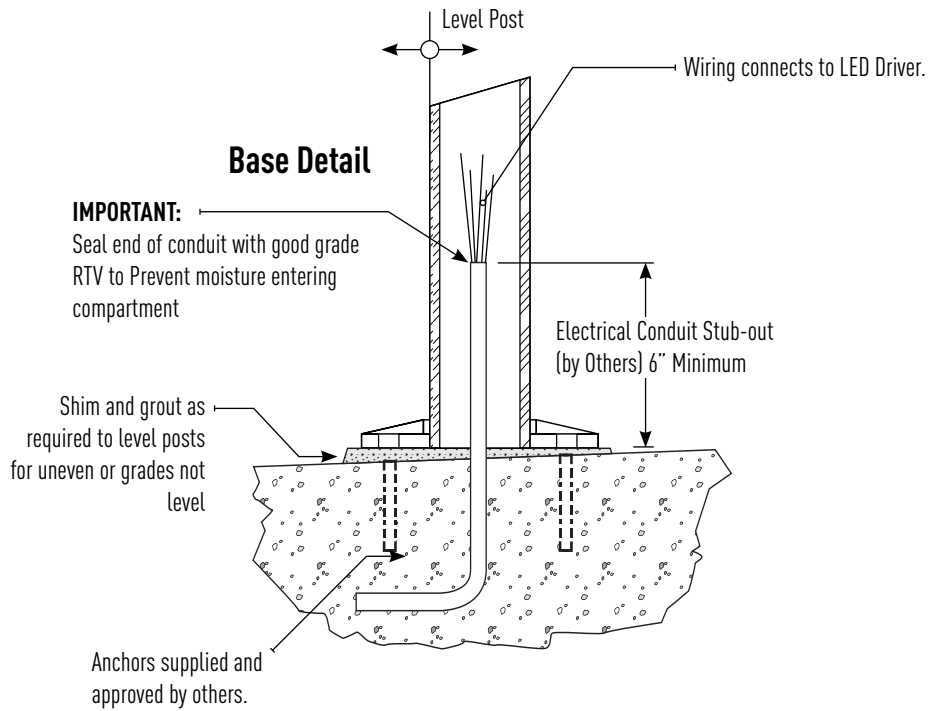

*Extension Tube Length Calculation (for straight sections).
 Dimension "V" - V-RAIL LED Lighted Section - 3.25" = Result ÷ 2 = Length Per Extension Tube*
 Example: 60" - 41.75" - 3.25" = 15 ÷ 2 = 7.5" Length Per Extension Tube*

V-Rail Installation Instructions

IVR2-SPI: 2" Slim Post Integral Power Supply (Post Mounted)

IS-V1003R4

4 of 4

Post Anchor Bolt Template

1:1 Scale

Do Not Fit or Scale To Page When Printing

