

# IVR15-RPS-WLC

1.5" Wildlife Certified V-Rail w/ Remote Power Supply

JOB NAME		CATALOG NUMBER	
NOTES		TYPE	

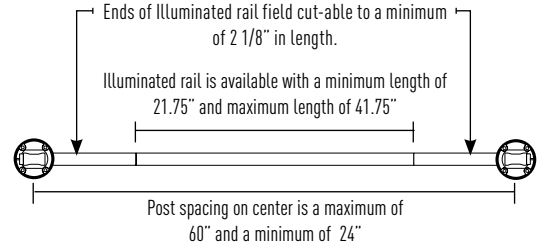
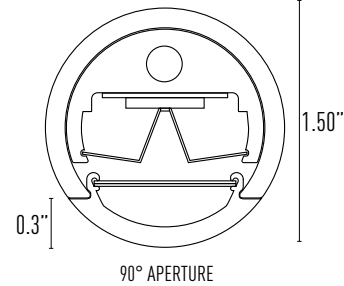

WAVELENGTH CHART

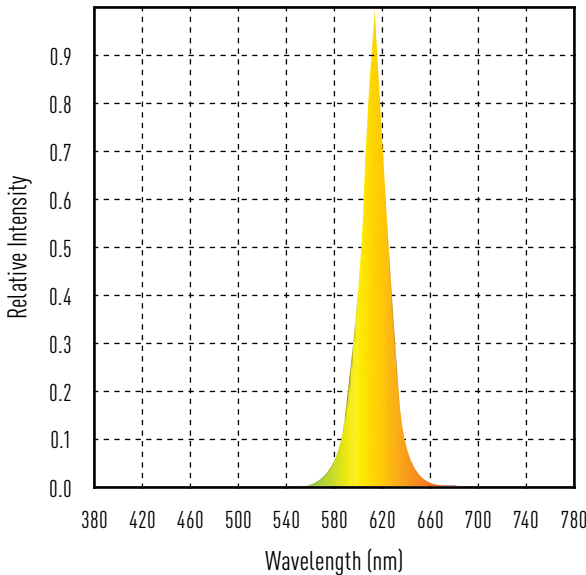

## FEATURES

The wildlife certified V-Rail is designed using amber LEDs that emit only within wavelengths safe for sea turtle navigation near coastal areas.

## CONSTRUCTION

**Internal Rail Construction:** Heavy duty extruded 6061-T6 Aluminum Alloy.

**External Rail Jacket:** Standard in 304 stainless steel, 316 stainless steel is recommended in marine environments, consult factory. Consult factory for custom powder coat finishes (AAMA 2604).

## MONOCHROMATIC LED LIGHT SOURCE

Closely packed array of small LEDs allow for smooth seamless illumination with immediate overlap to avoid pixilation and provide a continuous flow of light. Amber LED emits in long wavelengths greater than 580nm, and a range that doesn't disorient sea turtle hatchlings.

- 50,000 hours of average rated life at 70% output
- LED components are easily accessible to allow for easy maintenance

## LED LIGHT ENGINE (PER FOOT)

- System Power Consumption: 4.6W / per ft.

## OPTICAL SYSTEM

Innovative optical system includes integral reflector and light shaping diffuser. Diffuser provides a 92% transmission efficiency, control and distribution of light. Distributions include flood, narrow and asymmetric.

## REMOTE MOUNTING POWER SUPPLY

Configured per project requirements. Supplies 24V electronically stabilized power to LED's. U.L. Class 2 output for safe operation. Housed to NEMA rated enclosures. Intense Lighting provides shop drawings and specification to satisfy Architect and Electrical Contractor.

## MOUNTING / INSTALLATION

Each rail support is secured to the swivel mount on specified mounting system. Wall, post or embedded mount is available. See mounting submittal sheets for detailed information.

## EMERGENCY

Remote emergency inverter available. Can be remote up to 1000 ft. available. See IB-IIS specification sheet.

## WARRANTY / LISTINGS

- 5-Year Intense LED Limited Warranty (LED & Power Supply Only)
- ETL Wet Location Listed
- FWC Approved

# IVR15-RPS-WLC

## 1.5" O.D. Remote Post Mount Assembly

<b>JOB NAME</b>		<b>CATALOG NUMBER</b>	
<b>NOTES</b>		<b>TYPE</b>	

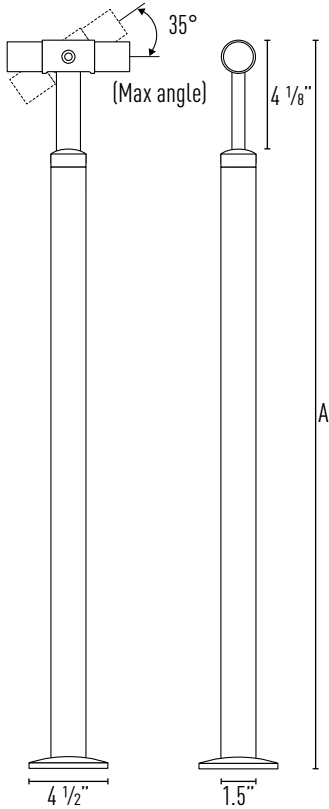

DIMENSIONS		
	Guardrail	Handrail
A	42"	36"

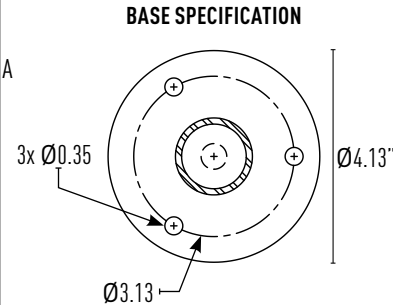

### CONSTRUCTION

Post mount assembly is available in No.4 polished 304 stainless steel. Consult factory for custom powder coat finishes (AAMA 2604).

### MOUNTING / INSTALLATION

Post are to be spaced at a maximum of 60" and minimum of 24" on centers. Post mount is to be surface mounted to concrete utilizing 5/16" anchor bolts (supplied by others). Anchoring means and size must be determined by local codes. Not to be supplied or engineered by Intense Lighting. See post mount installation chart for more information. Anchorage template available by request.

### FITTINGS

Consult factory for standard fittings and epoxy weld adhesive.

### INFILL OPTIONS (Consult Factory For Options & Configurations)



## Post Mount Installation Detail

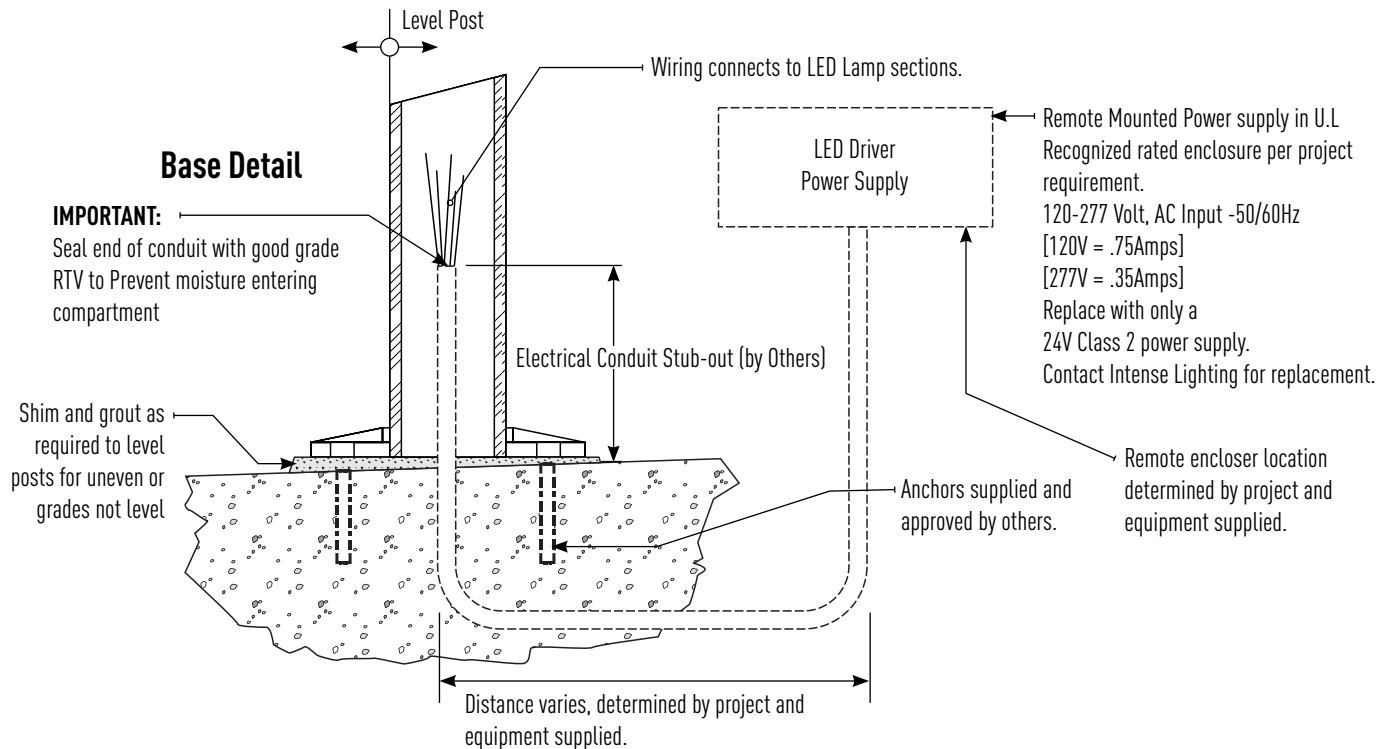

# IVR15-RPS-WLC

## 1.5" O.D. Remote Post Embedded Assembly

JOB NAME		CATALOG NUMBER	
NOTES		TYPE	

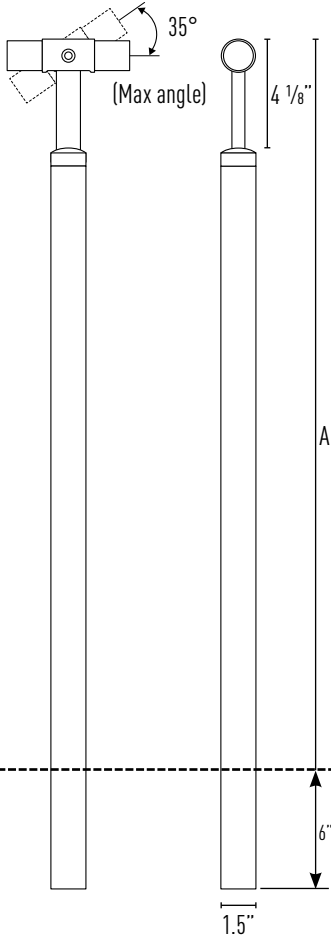

DIMENSIONS		
	Guardrail	Handrail
A	42"	36"

### CONSTRUCTION

Embedded mount assembly is available in No.4 polished 304 stainless steel. Consult factory for custom powdercoat finishes (AAMA 2604).

### MOUNTING / INSTALLATION

Post are to be spaced at a maximum of 60" and minimum of 24" on centers. Embedded mount post are set into place using Rockite® or Kwixset® anchor cement. A minimum of 6" post must be embedded into concrete to structurally secure post. Anchoring means and size must be determined by local codes. Not to be supplied or engineered by Intense Lighting. See Embedded Mount Installation chart for more information.

### FITTINGS

Consult factory for standard fittings and epoxy weld adhesive.

### INFILL OPTIONS (Consult Factory For Options & Configurations)



## Embedment Installation Detail

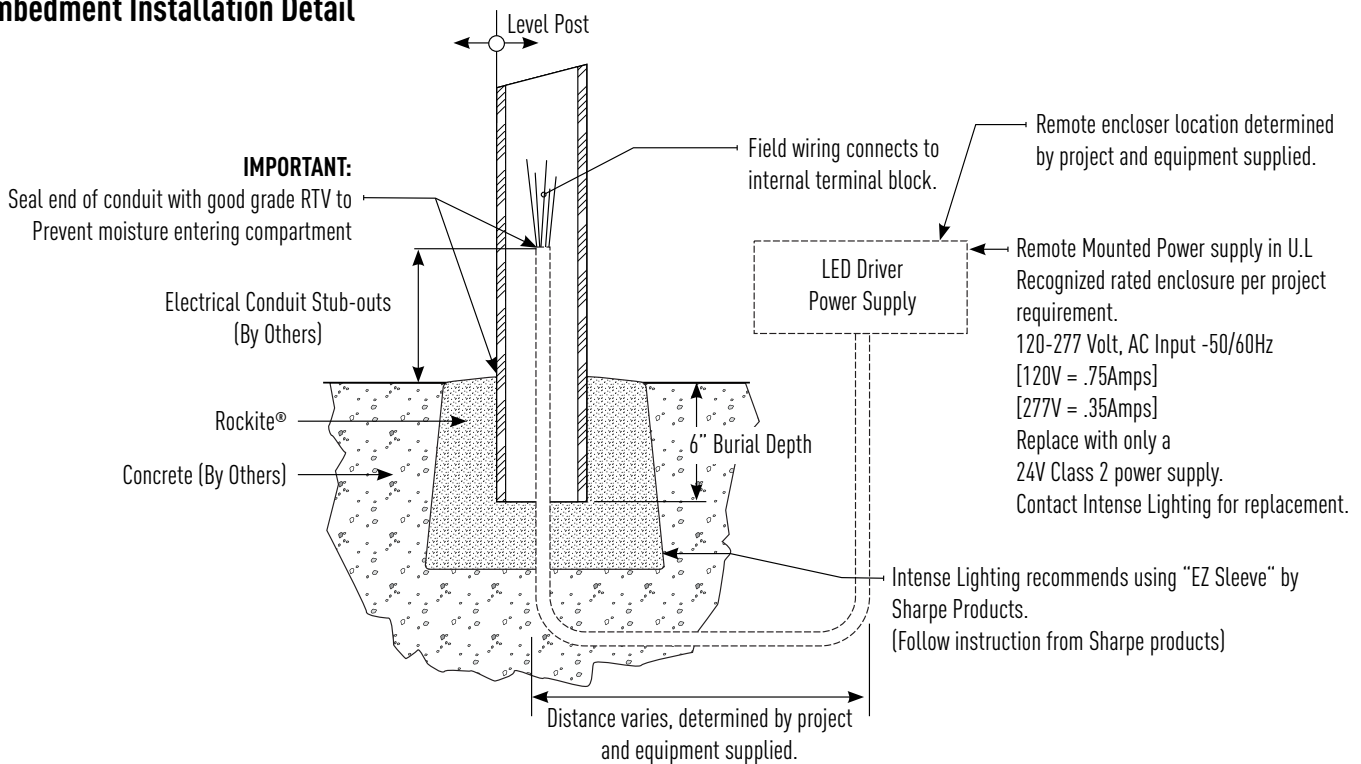

# IVR15-RPS-WLC

## 1.5" O.D. Remote Post Wall Mount Assembly

JOB NAME		CATALOG NUMBER	
NOTES		TYPE	

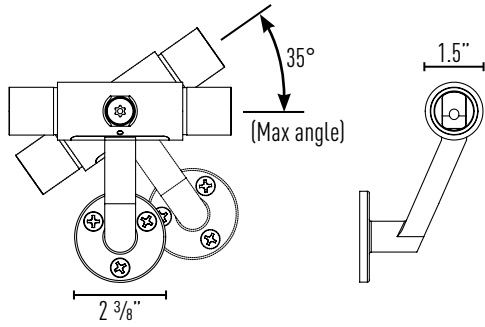

### CONSTRUCTION

Wall mount assembly is available in No.4 polished 304 stainless steel. Consult factory for custom powdercoat finishes.

### MOUNTING / INSTALLATION

Post are to be spaced at a maximum of 60" and minimum of 24" on centers. Wall mount assembly is to be mounted to concrete wall utilizing 1/4" anchor bolts (supplied by others). Anchoring means and size must be determined by local codes. Not to be supplied or engineered by Intense Lighting. See Wall Mount Installation chart for more information. Anchorage template available by request.

### FITTINGS

Consult factory for standard fittings and epoxy weld adhesive.

### WALL BRACKET SPECIFICATION

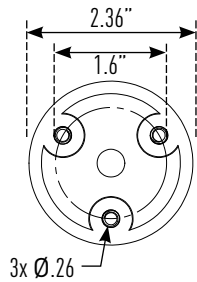

## Wall Mounted Installation Detail

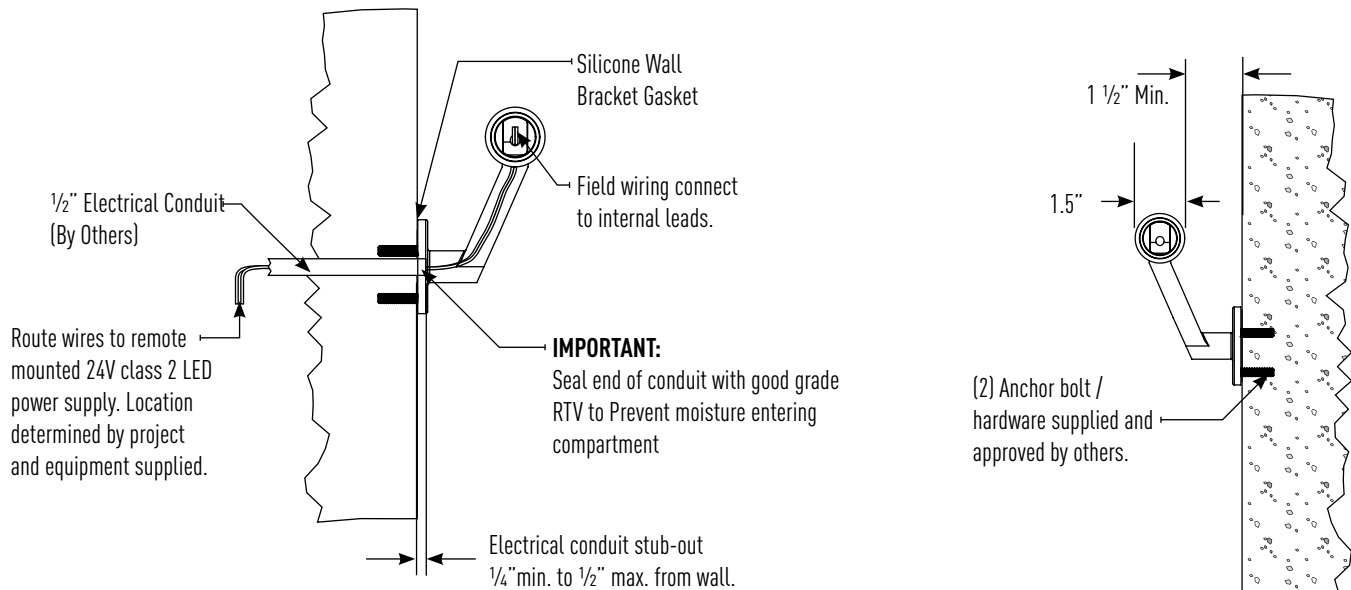

# IVR15-RPS-WLC

Remote Power Supply - Wet Location No Enclosure Required

JOB NAME		CATALOG NUMBER	
NOTES		TYPE	

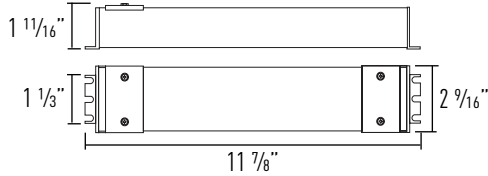

**IB-OT96** - 96W 24V Damp Location

**IB-OT96-DIM** - 96W 24V Damp Location 0-10V Dimming

### FEATURES

- Protected against open circuit, short circuit, overload and overheating issues
- Universal 120-277V input
- UL Wet location listed and FCC compliant
- Built in wiring compartments
- Integrated 0-10V dimming available

### MAX RUN LENGTH (POST ON 4' CENTER)

- High Output (HO) - 20'

### SPECIFICATIONS

- Input: 100-240VAC, 1.5-0.75A  
277VAC / 0.47A, 47-63Hz
- Output: 96W 24V / 4A
- Ambient Temperature Range: -22°F to 158°F (-30°C to 70°C)
- Weight: 2 lbs (.09 kg)
- Wiring: 18 AWG
- Classification: Class 2
- Protection Rating: IP66
- UL/cUL Recognized for damp location

## Maximum Mounting Distance (ft) to LED Input (at full load)

Power Supply	22 AWG	18 AWG	14 AWG	12 AWG
<b>IB-OT96</b>	7'	18'	46'	71'
<b>IB-ADV24V-347</b>	7'	18'	46'	71'

### Remote Wiring Limitation for Constant Voltage Power Supplies Due to EMI

All Constant Current power supplies are limited to **32ft maximum** remote mounting distance for EMI compliance (except NAED 51524 OT3/120-240/350 – 50ft).

Although it is possible to exceed the EMI limited remote mounting distance, it is the responsibility of the installer and/or end user to take precautions to prevent and/or test the effects of EMI on the installation. Additional EMC/EMI filters may be required on the output side of the power supply for compliance of installations above the limits given in Table 1.

# IVR15-RPS-WLC

## Remote Power Supply - Multiple Output Wet Location Enclosure

JOB NAME		CATALOG NUMBER	
NOTES		TYPE	

### Nema 4x UL Listed Outdoor Rated PVC Boxes

Non-Corroding, Non-Conducting, Fire Resistant, Concrete Tight



Suitable for Surface Mount and Recessed Mount

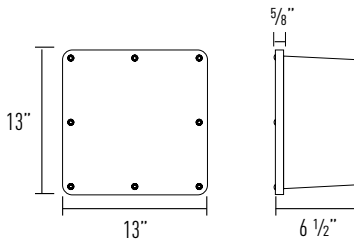

### LED Remote Power Supply "No Dimming"

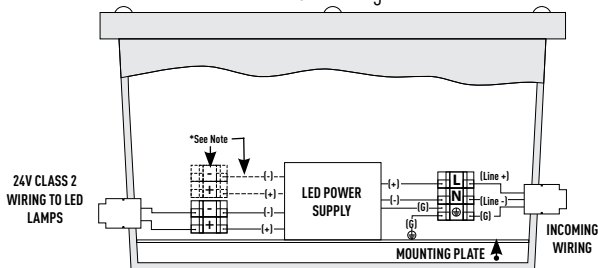

### LED Remote Power Supply "With Dimming"

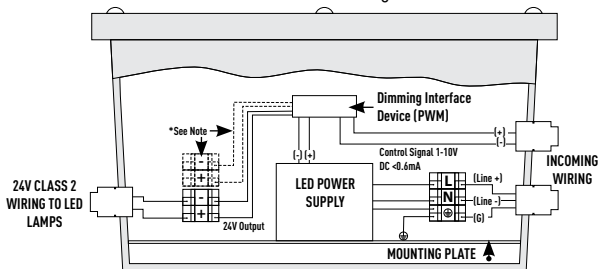

Wire gauge to be determined per project. Voltage drop occurs with distance. Any change in wire length requires re-engineering.

\*Notes: Dash lines represent additional outputs when supplied per project.

All components inside enclosure are supplied by Intense Lighting.

**IVR-RPS-1-0T96** - (1) 96W 120/277V (1) 24V Outputs

**IVR-RPS-2-0T96** - (2) 96W 120/277V (2) 24V Outputs

**IVR-RPS-3-0T96** - (3) 96W 120/277V (3) 24V Outputs

#### FEATURES

- Protected against open circuit, short circuit, overload and overheating issues
- Universal 120-277V input
- Suitable for damp and wet locations
- Easy connectivity to terminal blocks
- Integrated 0-10V dimming available

#### SPECIFICATIONS

- Input Power: 108-305VAC, 50/60 Hz, .91A @ 120VAC
- Output Power: 96W 24V DC
- Ambient Temperature Range: -22°F to 158°F (-30°C to 70°C)
- Classification: Class 2
- Protection Rating: IP66

**IVR-RPS-1-ADV24V-347** - (1) 96W 347V (1) 24V Outputs

**IVR-RPS-2-ADV24V-347** - (2) 96W 347V (2) 24V Outputs

**IVR-RPS-3-ADV24V-347** - (3) 96W 347V (3) 24V Outputs

#### FEATURES

- Protected against open circuit, short circuit, overload and overheating issues
- Ideal for projects in USA with 480V input
- Ideal for projects in Canada with 347V input

#### SPECIFICATIONS

- Input Power: 347-480VAC,
- Output Power: 100W 24V DC
- Ambient Temperature Range: -40°C to 65°C
- Classification: Class 2
- Protection Rating: IP66

# IVR15-RPS-WLC

## 1.5" Wildlife Certified V-Rail w/ Remote Power Supply

<b>JOB NAME</b>		<b>CATALOG NUMBER</b>	
<b>NOTES</b>		<b>TYPE</b>	

**V-Rail Part Number (Example: IVR15-RPS-WLC-ST-W-H0-60S)**  
(Specify Quantity By Foot)

A: Family	B: Finish	C: Mounting/Height	D: LED Output	E: Light Distribution	F: Electrical	G: Options
<b>IVR15-RPS-WLC</b>	-ST (304 Stainless Steel) <sup>1</sup> -C (Custom) <sup>2</sup>	-W (Wall Mount) -P36 (36" Post Mount) -P42 (42" Post Mount) -E36 (36" Embedded Mount) -E42 (42" Embedded Mount)	-HO (High Output 4.6W) -NL (No LED - Rail Only) <sup>3</sup>	-60S (60° Flood) -35S (35° Narrow) -30AS (30° Asymmetric)	blank (24V Input)	-I (InfilU) <sup>2</sup>

**Notes:**

1. 316 Stainless steel available by special order
2. Special order, consult factory
3. No LED (rail only). Please omit sections E, F and G

## Specification and Delivery Process

Architectural drawings or detailed elevation drawings are required for a V-Rail quotation. Once an order is placed, Intense Lighting will provide detailed shop drawings for approval.

V-Rail will be delivered to the job site ready for installation. A detailed assembly drawing will be provided along with dimensions and locations for remote power supplies. All products included will be labeled clearly to match the assembly drawing. Certain tools and equipment will be required for the assembly of V-Rail. A detailed list of tools can be found in the V-Rail Installation Guide. Installation guide available upon request, consult factory.

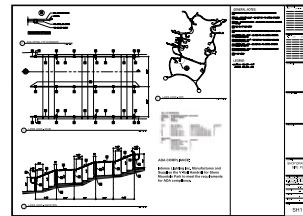

*Shop Drawing / Assembly Guide*



*Completed Project*

**Notes:**