

IVR15-SPI-WLC

1.5" Wildlife Certified V-Rail w/ 2" Post Integral Power Supply

JOB NAME		CATALOG NUMBER	
NOTES		TYPE	

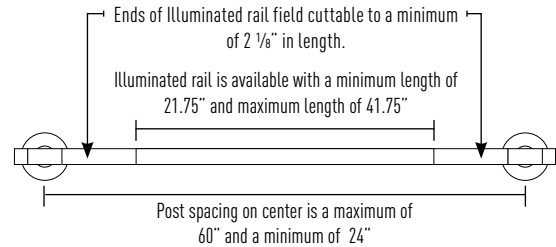
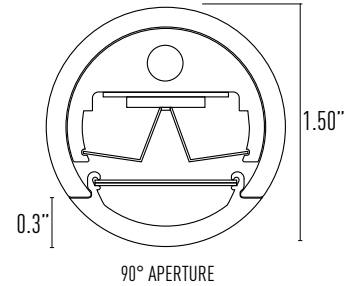

WAVELENGTH CHART

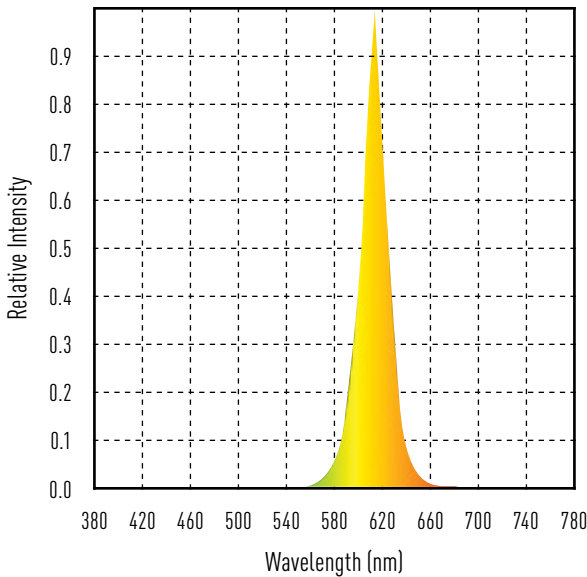

FEATURES

The wildlife certified V-Rail is designed using amber LEDs that emit only within wavelengths safe for sea turtle navigation near coastal areas.

CONSTRUCTION

Internal Rail Construction: Heavy duty extruded 6061-T6 Aluminum Alloy.

External Rail Jacket: Available in 304 or 316 stainless steel. Consult factory for custom powder coat finishes (AAMA 2604).

MONOCHROMATIC LED LIGHT SOURCE

Closely packed array of small LEDs allow for smooth seamless illumination with immediate overlap to avoid pixilation and provide a continuous flow of light. Amber LED emits in long wavelengths greater than 580nm, and a range that doesn't disorient sea turtle hatchlings.

- 50,000 hours of average rated life at 70% output
- LED components are easily accessible to allow for easy maintenance

LED LIGHT ENGINE (PER FOOT)

- System Power Consumption: 4.6W / per ft.

OPTICAL SYSTEM

Innovative optical system includes integral reflector and light shaping diffuser. Diffuser provides a 92% transmission efficiency, control and distribution of light. Distributions include flood, narrow and asymmetric.

MOUNTING / INSTALLATION

Each rail support is secured to the swivel mount on specified mounting system. Post or embedded mount is available. See mounting submittal sheets for detailed information.

EMERGENCY

Remote emergency inverter available. Can be remote up to 1000 ft. available. See IB-IIS specification sheet.

WARRANTY / LISTINGS

- 5-Year Intense LED Limited Warranty (LED & Power Supply Only)
- ETL Wet Location Listed
- IDA Approved
- ADA Compliant
- FWC Approved

IVR15-SPI-WLC

2" Post Mount Assembly

JOB NAME		CATALOG NUMBER	
NOTES		TYPE	

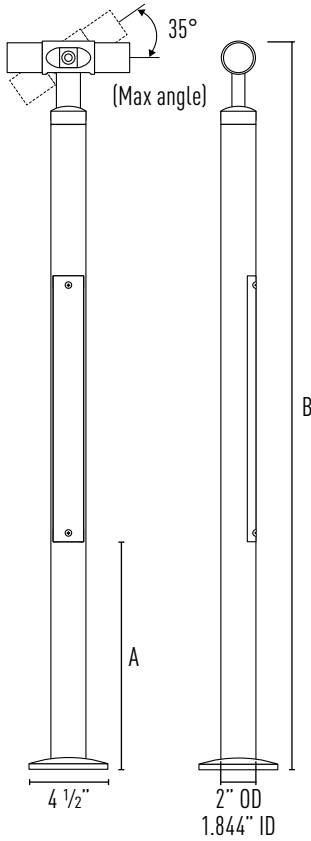

	DIMENSIONS	
	Guardrail	Handrail
A	17"	14"
B	42"	36"

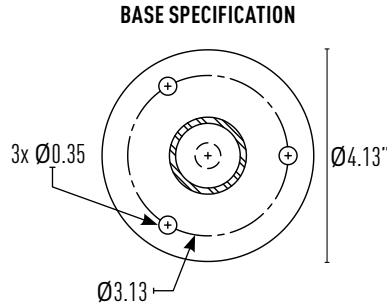

CONSTRUCTION

Post mount assembly is available in No.4 polished 304 stainless steel. Consult factory for custom powder coat finishes (AAMA 2604).

MAINTENANCE

Posts include a driver access door where power supply components are easily accessible. Tamper proof hardware and special tools are standard and included.

MOUNTING / INSTALLATION

Post are to be spaced at a maximum of 60" and minimum of 24" on centers. Post mount is to be surface mounted to concrete utilizing 3/8" anchor bolts (supplied by others). Anchoring means must be determined by local codes. Not to be supplied or engineered by Intense Lighting. See post mount installation chart for more information. Anchorage template available by request.

INFILL OPTIONS (Consult Factory For Options & Configurations)

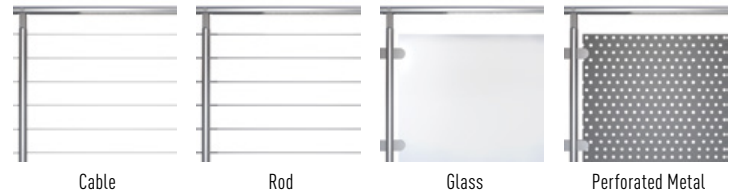

OPERATION

Post with integral power supply will power up-to 83 1/2" of illuminated rail.

FITTINGS

Consult factory for standard fittings and epoxy weld adhesive specification.

Post Specification

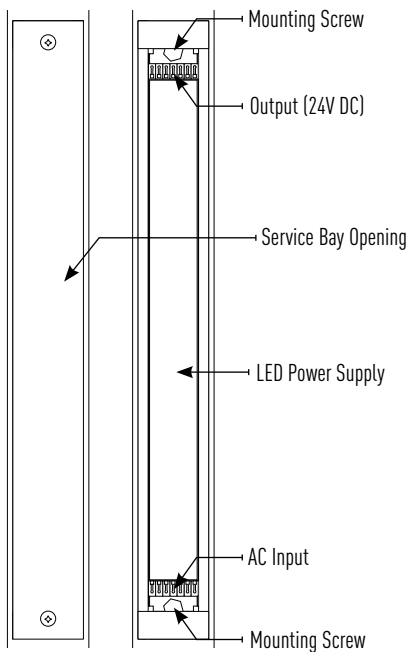

Post Mount Installation Detail

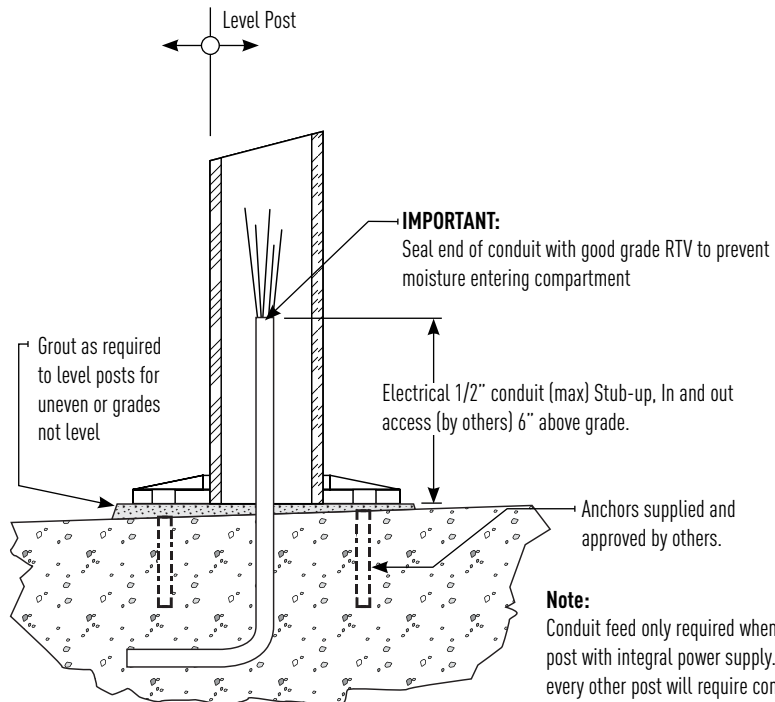

Note:

Conduit feed only required when installing post with integral power supply. Typically every other post will require conduit feed.

IVR15-SPI-WLC

2" Post Embedded Assembly

JOB NAME		CATALOG NUMBER	
NOTES		TYPE	

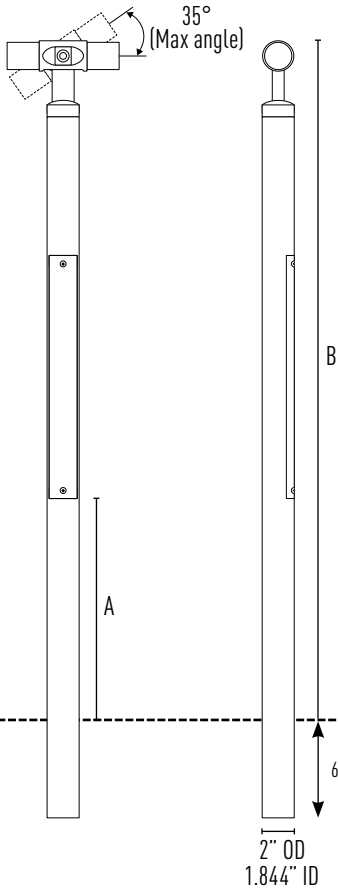

	Guardrail	Handrail
A	17"	14"
B	42"	36"

CONSTRUCTION

Post mount assembly is available in No.4 polished 304 stainless steel. Consult factory for custom powder coat finishes (AAMA 2604).

MAINTENANCE

Posts include a driver access door where power supply components are easily accessible. Tamper proof hardware and special tools are standard and included.

MOUNTING / INSTALLATION

Post are to be spaced at a maximum of 60" and minimum of 24" on centers. Embedded mount post are set into place using Rockite® or Kwixset® anchor cement. A minimum of 6" post must be embedded into concrete to structurally secure post. Anchoring means must be determined by local codes. Not to be supplied or engineered by Intense Lighting. See Embedded Mount Installation chart for more information.

OPERATION

Post with integral power supply will power up-to 83 1/2" of illuminated rail.

FITTINGS

Consult factory for standard fittings and epoxy weld adhesive specification.

INFILL OPTIONS (Consult Factory For Options & Configurations)



Post Specification

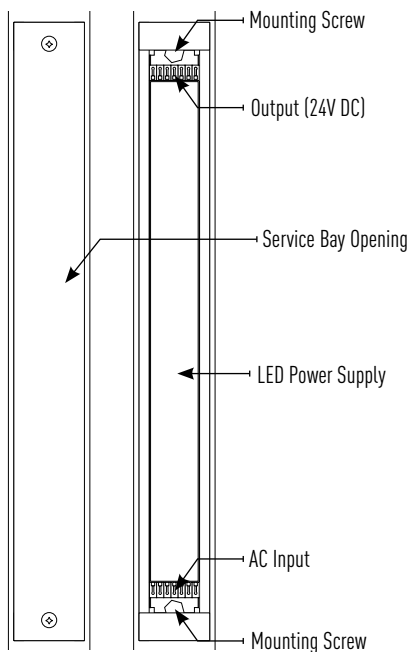

Embedded Installation Detail

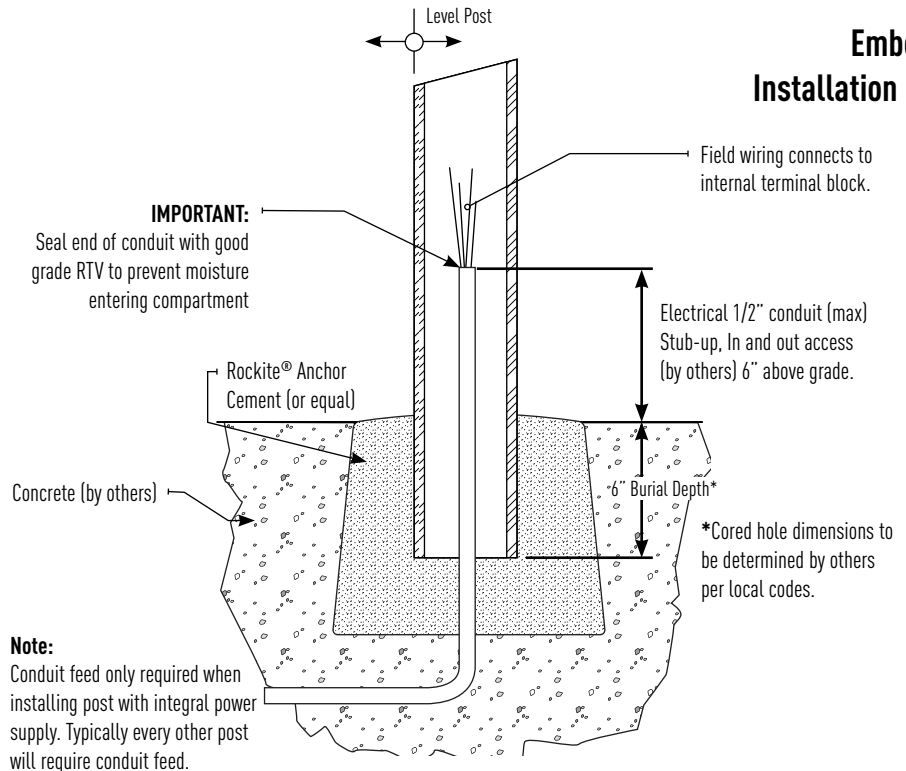

IVR15-SPI-WLC

1.5" Wildlife Certified V-Rail w/ 2" Post Integral Power Supply Specification Guide

JOB NAME		CATALOG NUMBER	
NOTES		TYPE	

V-Rail Part Number (Example: IVR15-SPI-WLC-ST-P42-HO-30AS)
(Specify Quantity By Foot)

A: Family	B: Finish	C: Mounting/Height	D: LED Output	E: CCT	F: Light Distribution	G: Electrical	H: Options
IVR15-SPI-WLC	- ST (304 Stainless Steel) ¹ - C (Custom) ²	- P36 (36" Post Mount) - P42 (42" Post Mount) - E36 (36" Embedded Mount) - E42 (42" Embedded Mount)	- HO (High Output 4.6W)	blank (Wildlife Certified Amber)	- 60S (60° Flood) - 35S (35° Narrow) - 30AS (30° Asymmetric)	blank ERP VLM Series 120/277V Input Driver - LUT Lutron LTEA 2-Wire 1% Dim 120V Input Driver	- I (Infill) ²

Notes:

1. 316 Stainless steel available by special order
2. Special order, consult factory
3. No LED (rail only), see IVR15-RPS

Specification and Delivery Process

Architectural drawings or detailed elevation drawings are required for a V-Rail quotation. Once an order is placed, Intense Lighting will provide detailed shop drawings for approval.

V-Rail will be delivered to the job site ready for installation. A detailed assembly drawing will be provided along with dimensions and locations for remote power supplies. All products included will be labeled clearly to match the assembly drawing. Certain tools and equipment will be required for the assembly of V-Rail. A detailed list of tools can be found in the V-Rail Installation Guide. Installation guide available upon request, consult factory.

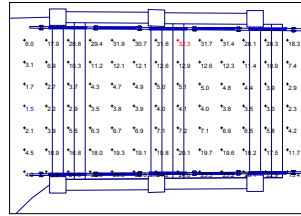

Photometric Layout

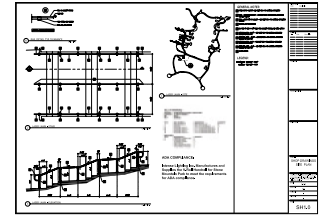

Shop Drawing / Assembly Guide



Completed Project

Notes: